

# 102-0215 & 103-0215 7" Aluminum Systems

## Installation Instructions

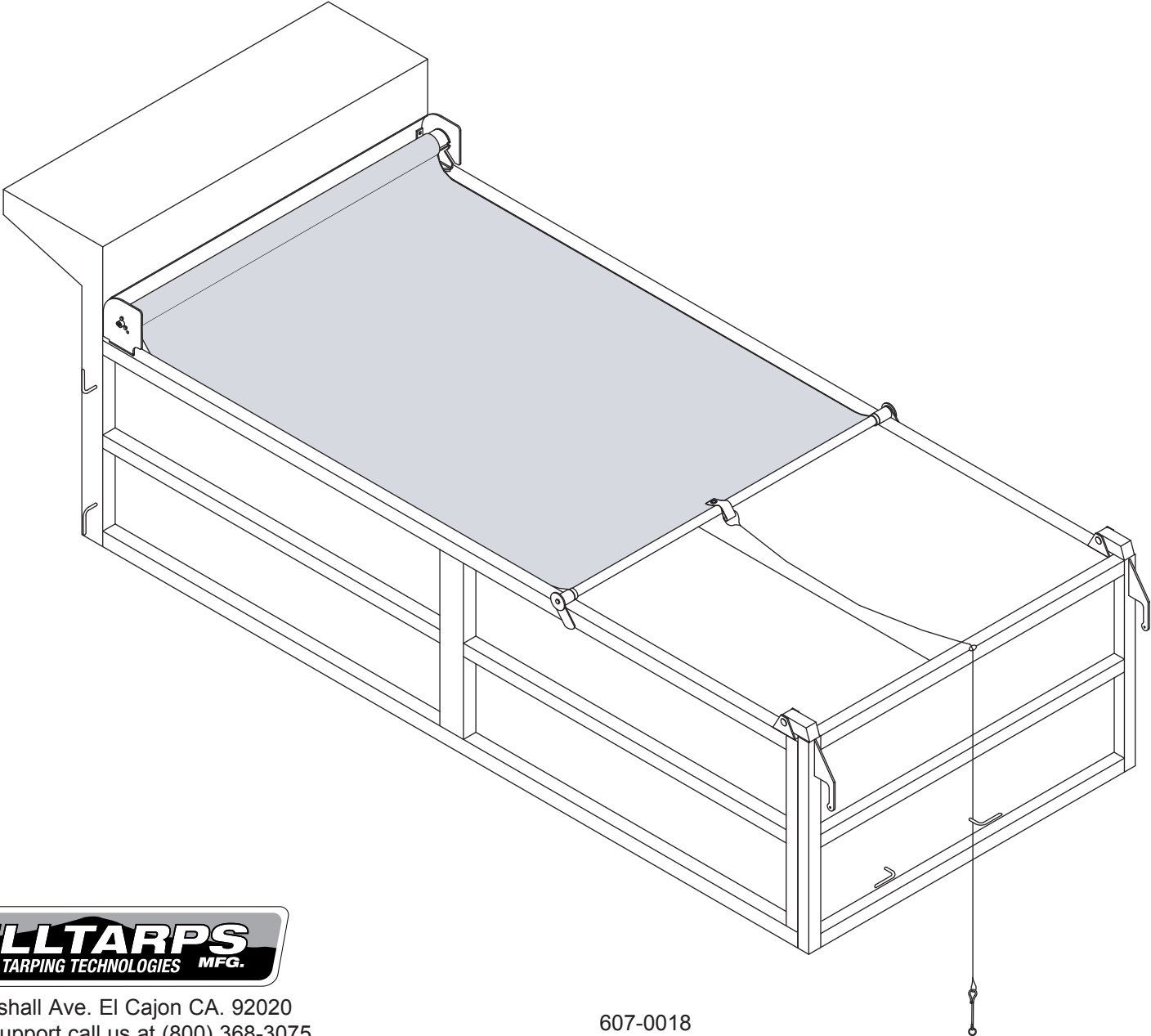

1404 N. Marshall Ave. El Cajon CA. 92020  
For technical support call us at (800) 368-3075

607-0018

NB 12/13/11

**Step 1. Mounting Positions**

Determine the mounting position for your truck Fig. 1 - Fig. 7.

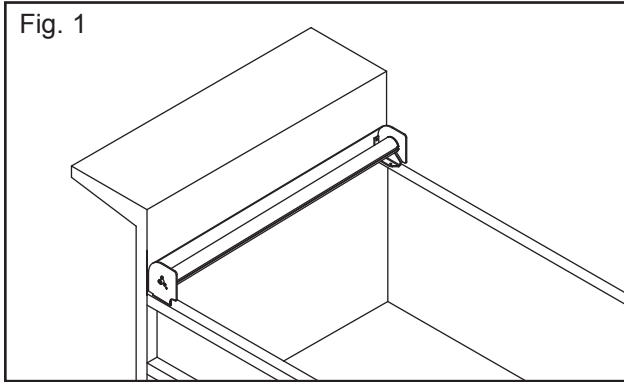

"A" Mount Top or Bottom Roll

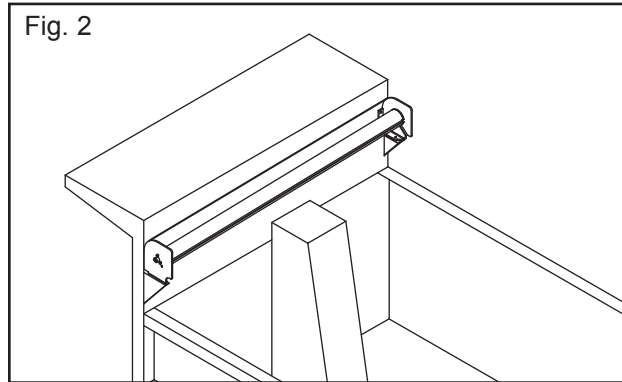

"B" Mount Top or Bottom Roll

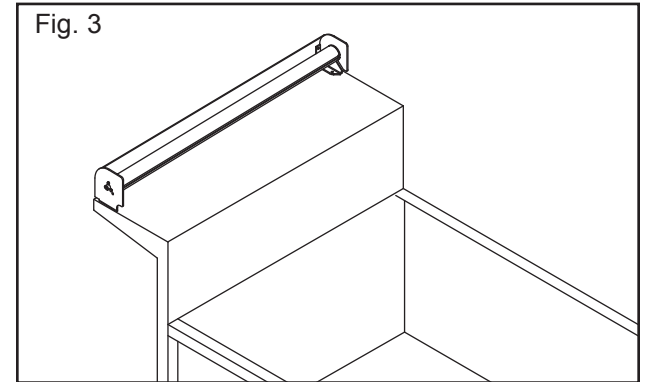

"C" Mount Top or Bottom Roll

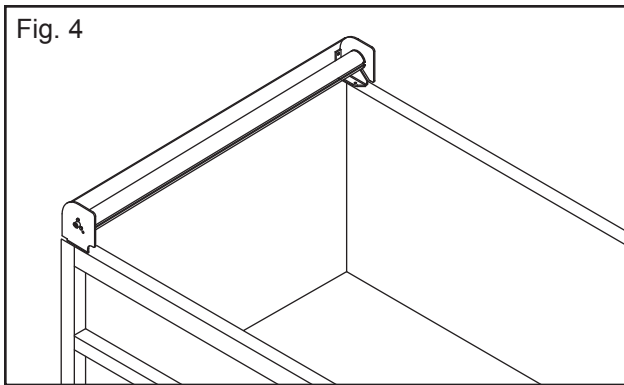

"D" Mount Top or Bottom Roll

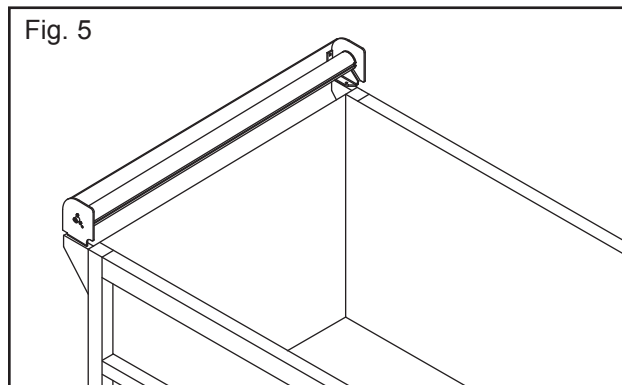

"E" Mount Top or Bottom Roll

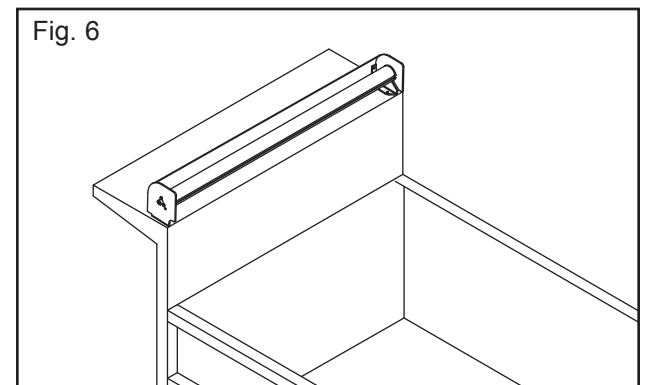

"F" Mount Top or Bottom Roll

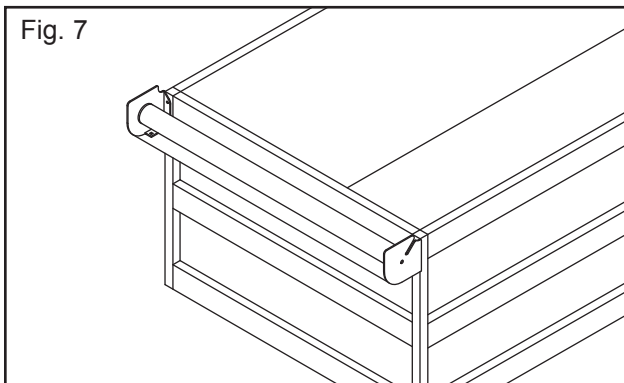

"G" Mount Top Roll Only

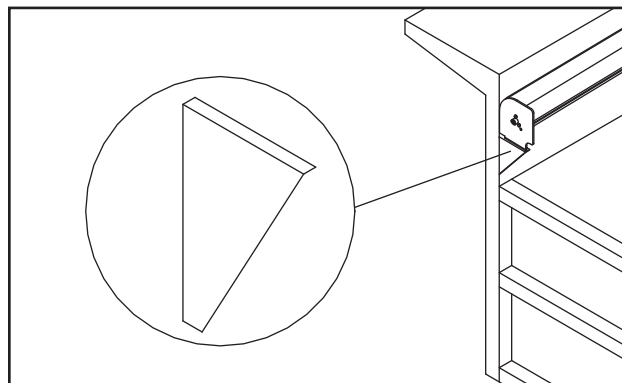

"B" Brackets

NOTE: Use optional "B" Brackets when mounting in position "B" and "E".

**Step 2A. Remove Tarp Before Welding**

\*Before welding remove tarp to avoid damage (Fig. 9A)\*

To remove tarp, pull the tarp all the way out over the tailgate. Insert 3/8" x 3" bolt into groove on roller tube making sure the bolt head rests against front edge of end plate. This will lock spring tension in roller tube. Slide tarp out of roller tube and away from work area.

Fig. 8

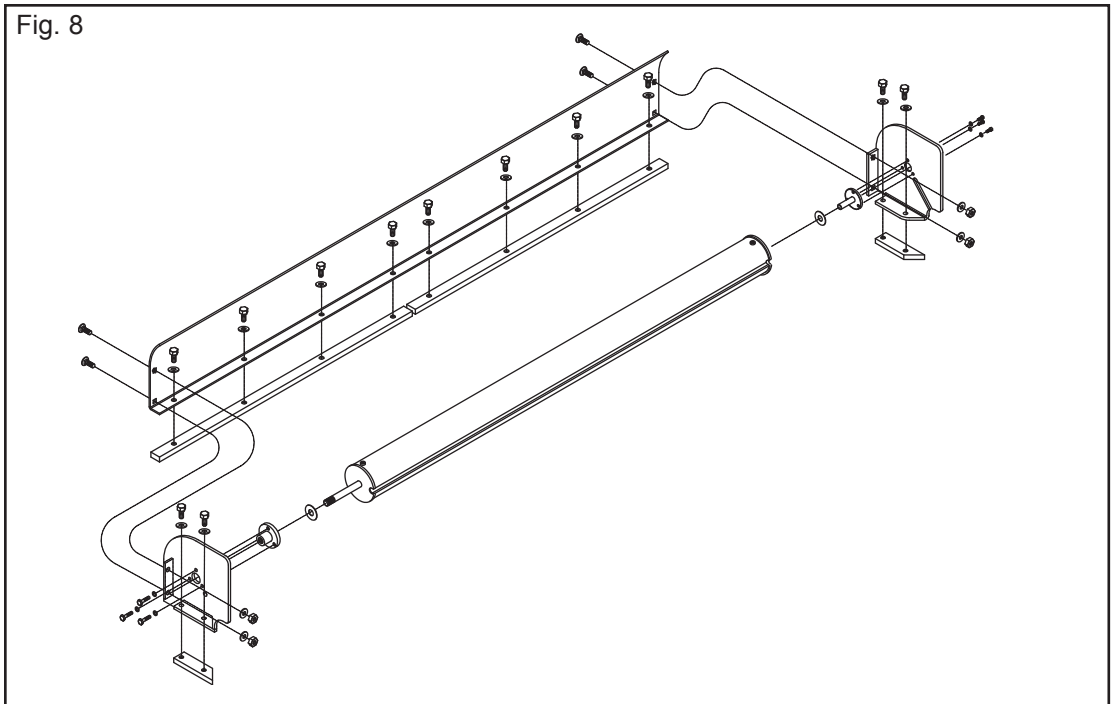
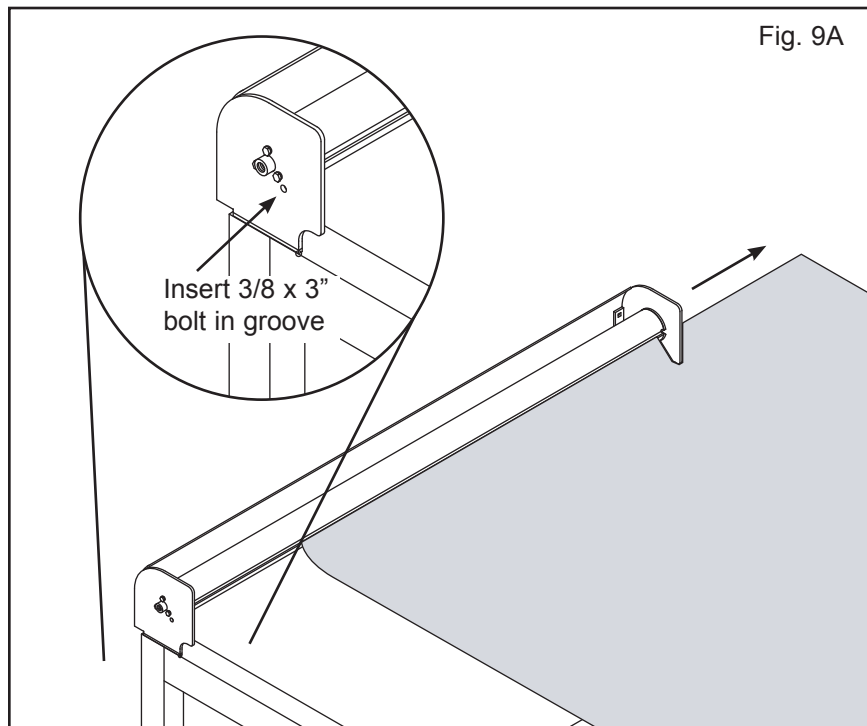

Fig. 9A



**Step 2B. Weld System To Truck**

Weld system mounting bar to truck as shown in Fig. 9B.

Fig. 9B

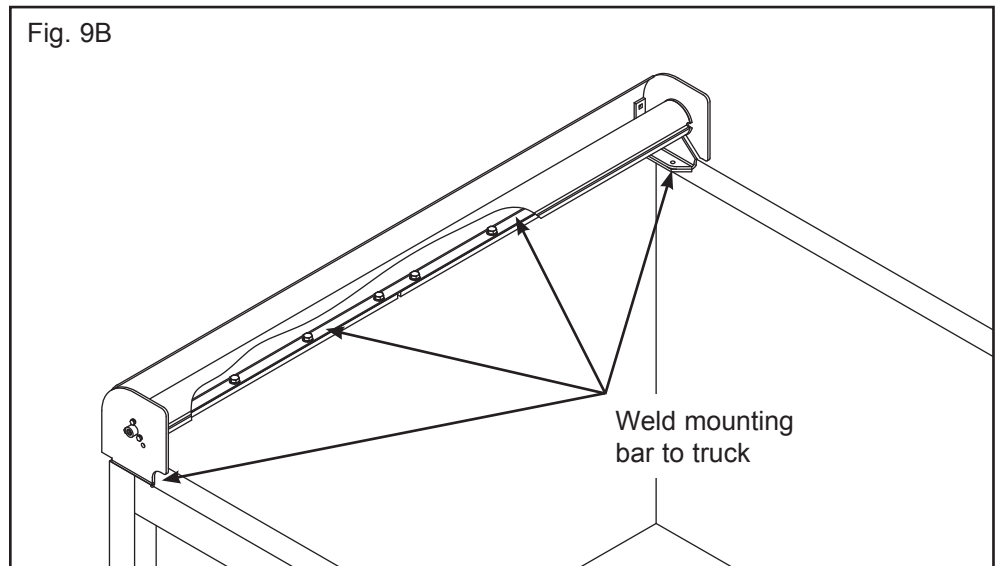

### Step 3. Dimple Tailgate for Rope Guide

Check the top of the tailgate where your tarp goes over for any obstructions that may interfere with the tarp laying flat all the way across the tailgate area.

**WARNING:** Sharp Edges May Cut Tarp.

Measure tailgate to find center and mark. Heat at mark with torch until area is red hot. Use a 3/4" diameter solid bar and lay it on the spot and strike it a few times. A smooth indentation should be left that will keep the rope centered. (Fig.10) & (Fig.11)

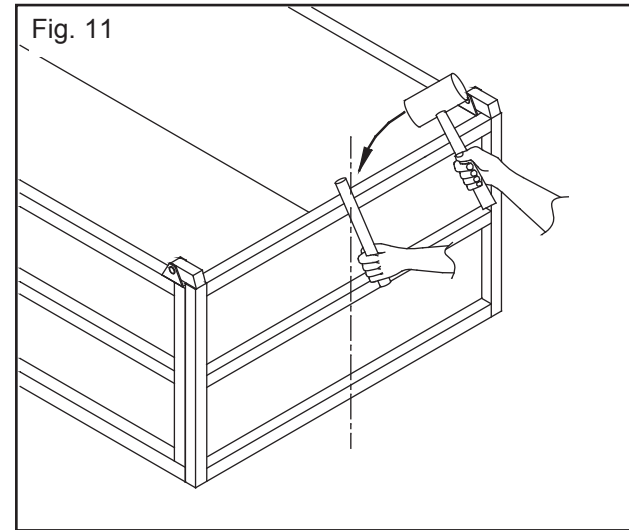
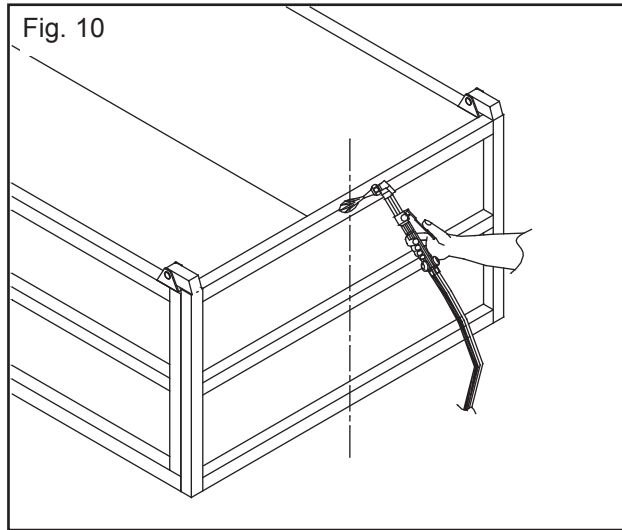

### Step 4. Weld on Tarp Return Ramps

The Tarp Return Ramps hold the pullrod in place once the tarp has been deployed. The ramps should be welded as high as possible.

See (Fig.12 & Fig.13 for your application). Make sure all rough edges are ground smooth. If you have a raised hinge you will need to add a Hinged Ramp Gusset (NOT SUPPLIED) see (Fig.14).

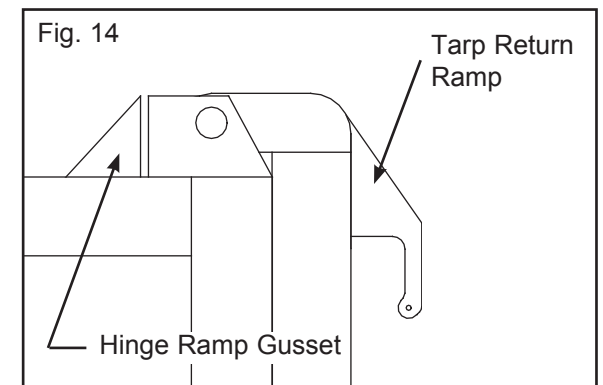
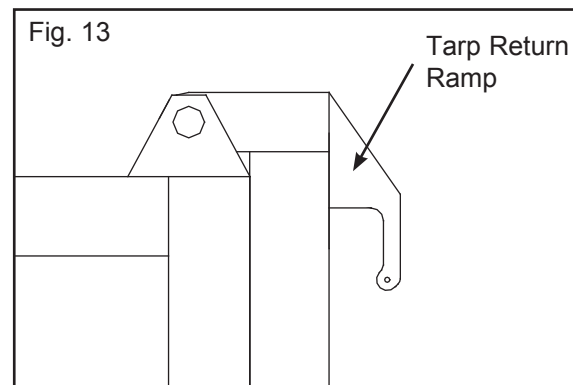
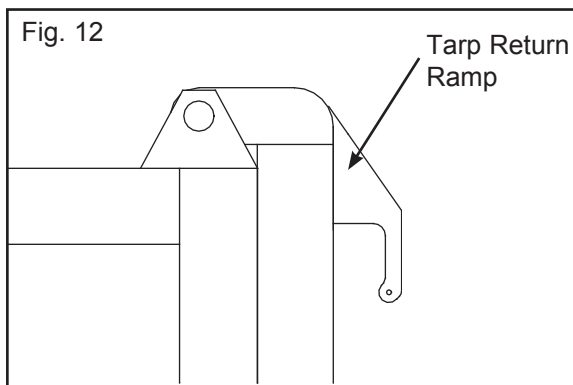

### Step 5. Tarp Return Ramps for Belly Dumps

All belly dumps require special tarp return ramps. If you are not sure which type to use, call us at Pulltarps (800) 368-3075 for technical support.

#### Jump Ramp

On longer single units, you are too far from the return ramp to unlatch the Pullrod by hand so we developed the easy to operate Jump Ramp (Fig. 15). Pull the tarp out all the way. Lower your arm. Release some rope slowly and allow the Pullrod to slide forward and drop down into the Tarp Return Ramp.

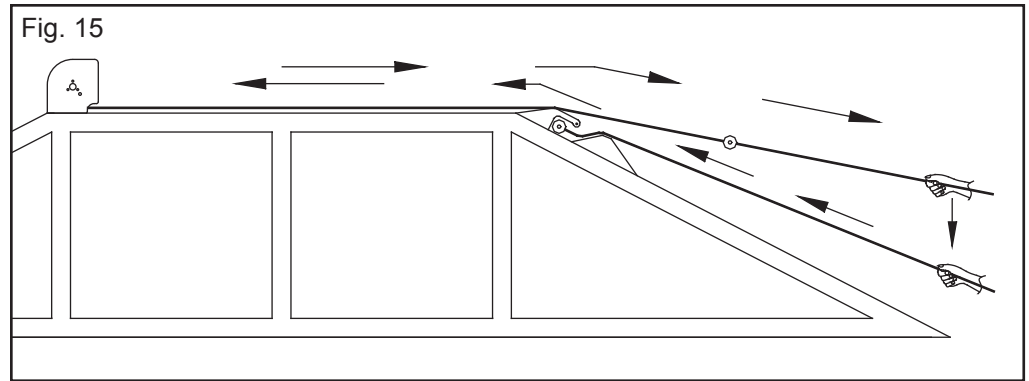

1. Pull out and hook. (Fig. 16)

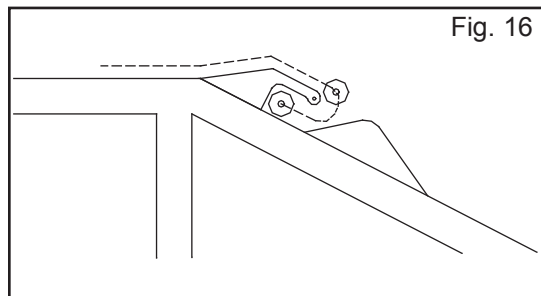

2. To retract, pull the pullrod up over the jump-ramp gusset and down a few inches. (Fig. 17)

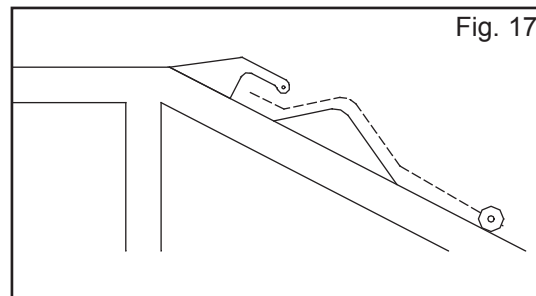

3. Release a few feet of rope quickly and the spring in the roller will cause the Pullrod and tarp to jump over the return ramp and retract back to the system (Fig. 18).

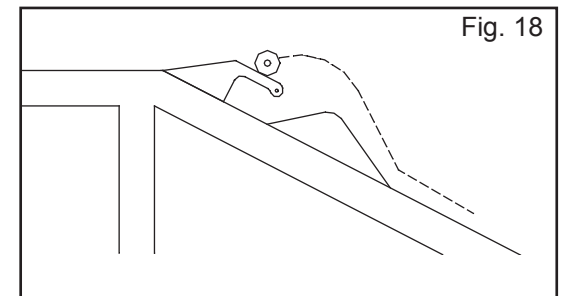

On long belly dumps with short vertical sideboards, use the finger tarp return ramps. Weld the provided gussets to the box to create a Pullrod jump ramp (Fig. 19)

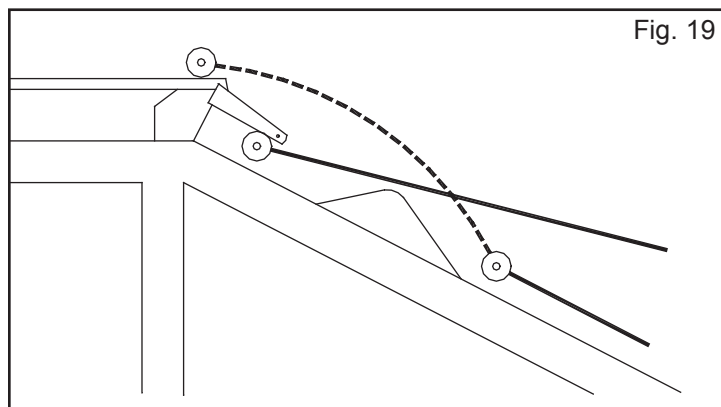

On short belly dumps, pull the tarp all the way out. Raise and lower to hook and unhook the Pullrod over the finger tarp return ramps (Fig. 20)

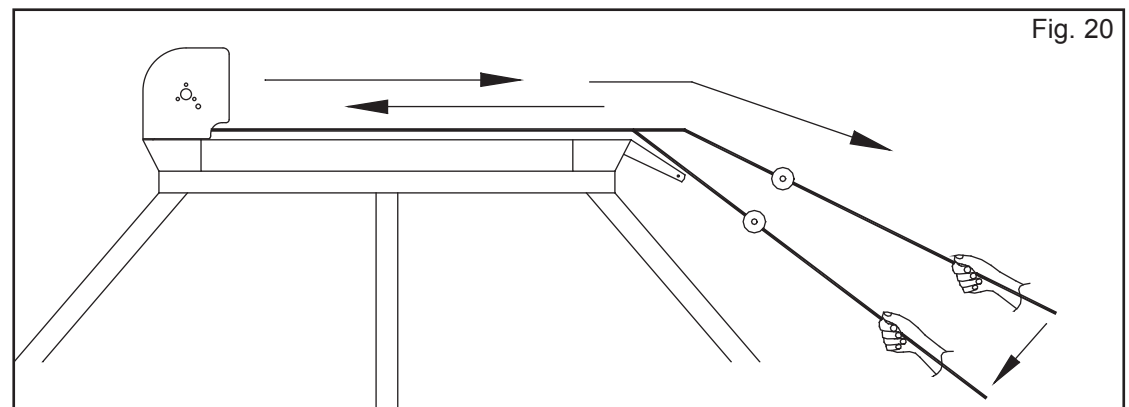

**Step 6. Re-install Tarp**

Before you re-install your tarp on the roller, make sure the roller has not lost its spring tension. If the roller is still locked with the locking bolt, the tension should have been maintained. Slide the front end of tarp (with beaded rod) into the slot of the roller from the opposite side of the locking bolt. If needed, lubricate the edge of the tarp with soapy water so it will slide into the roller slot easy. After the tarp is in place, make sure that it is centered on the roller with an equal amount of space on each end, and that the bead tubing is also equally spaced. Secure tarp and pullrod to tailgate with the pullrope. Hold the roller with one hand and remove the locking bolt with the other. Release pullrope from tailgate and cycle the tarp 2 or 3 times. This will ensure the tarp rolling up straight. If the tarp rolls up consistently off to one side or the other, you can offset the tarp to the opposite side on the roller to start with, this way the tarp will roll up as centered as possible. If you have side flaps or tie downs proceed to page 7 or 8.

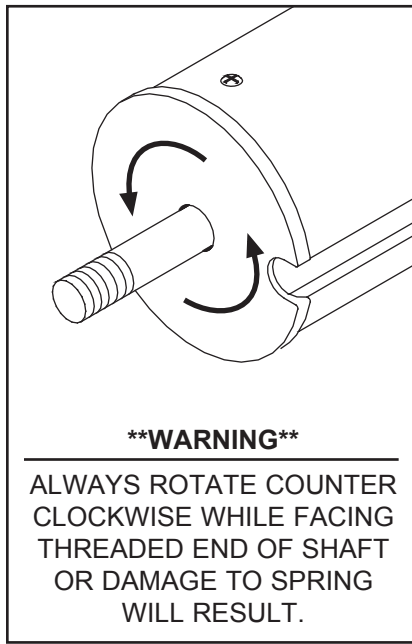

The roller comes pre-loaded from the factory. Should the roller lose tension for any reason during installation, you must pre-load the spring mechanism again before installing the tarp.

**IF ROLLER HAS LOST SPRING TENSION**

1. Locate the threaded end of the roller shaft.
2. Rotate roller tube counter clockwise by hand 4 to 5 times until you feel some spring resistance.
3. Count the number of turns from that point.

	Approximate Pre-load Turns		
Tarp Length	4M	5.5M	7.5M
Turns	13Ft.	18Ft.	25Ft.
	25/30	30/35	35/40

Flaps (Longer tarps with flaps may require an additional 5 to 10 turns)

4. If the tarp doesn't wind up all the way add 5 turns at a time until tarp winds up completely. If the tarp still won't wind up after 60 turns call (800) 368-3075

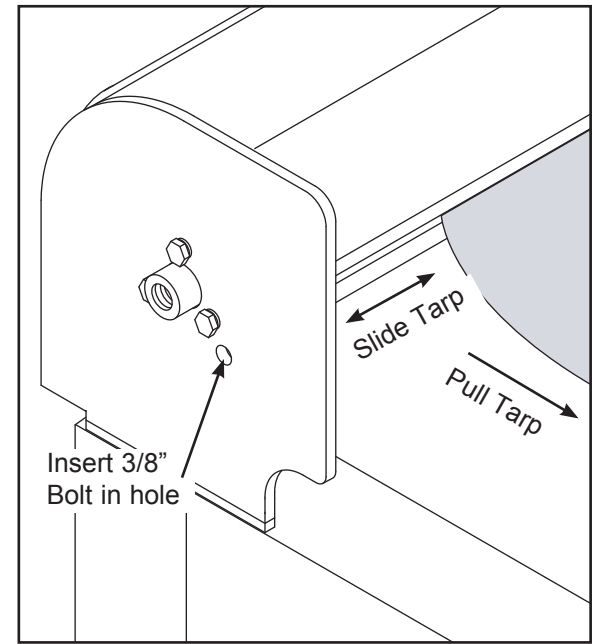

**Step 7. Rope Storage Hook Installation**

Mount the rope as low as possible. The rope should come straight down and wrap around the center hook and then coil off to the side (Fig.21).When tarp is not in use, space the hooks far enough apart to store the full

length of rope (Fig.22).

**Note: Tarp must be retracted when dumping**

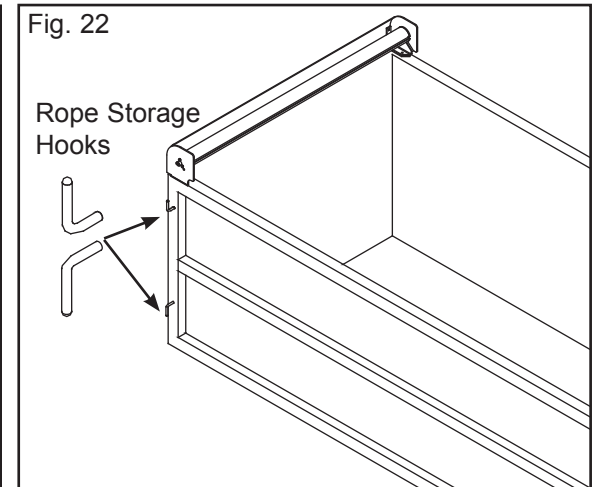
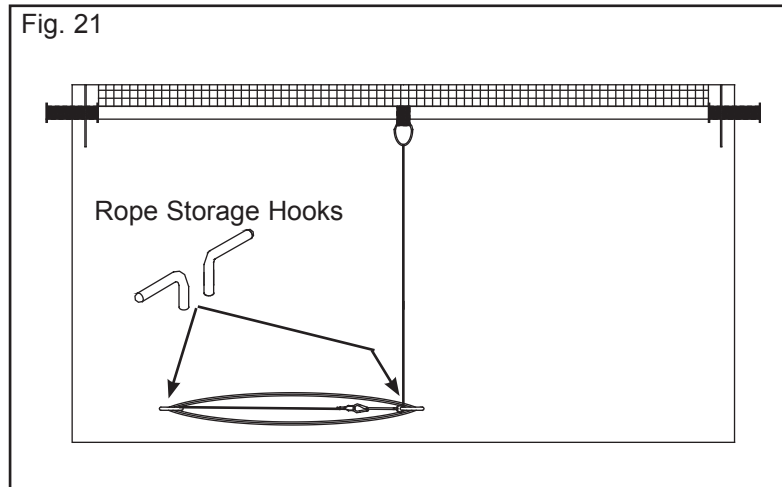

## Step 8. Optional Tie Down Tarp, Rope and Hook Installation

Parts: Tie Down Hooks (Steel or Alum.)

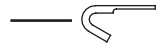

Pull Down Hook



### The Location Of The Tie Down Hooks Is Critical !

Flip the braided rope over the corner so that the rope and tie down flaps hang over each side of the box. The number of tie down hooks vary depending on the length of your tarp. One pull down hook is included with your Pulltarp system. If needed. Use the hook to pull the braided rope and tie down flap over the side of the box.

### The tie down hooks must be positioned so that:

- The tie down rope can be reached from the ground.
- The bungee cord has to be stretched to reach the last hook (see step 9).
- The rope has no slack.
- The tie down hooks are level with one another.

To ensure proper hook placement, first duct tape the rope to the box in place of the tie down hooks. Start with hook closest to the cab.

- Position the first hook 2" (5.08cm) forward of first tie down (Fig.23).
- Position middle hook between tie downs (Fig.24).
- Position last hook at the end of the box (Fig.25).
- Weld hooks in place level with one another.

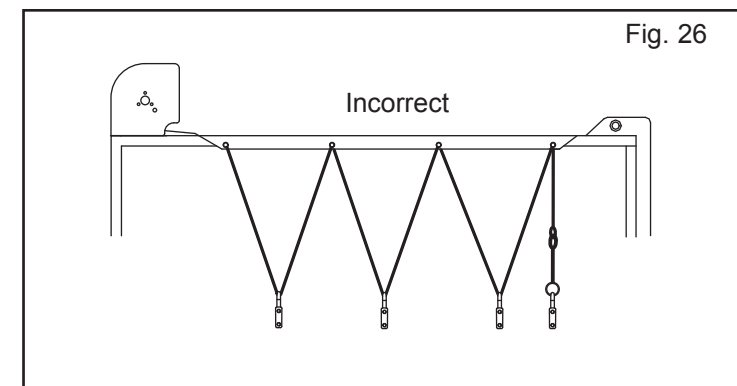
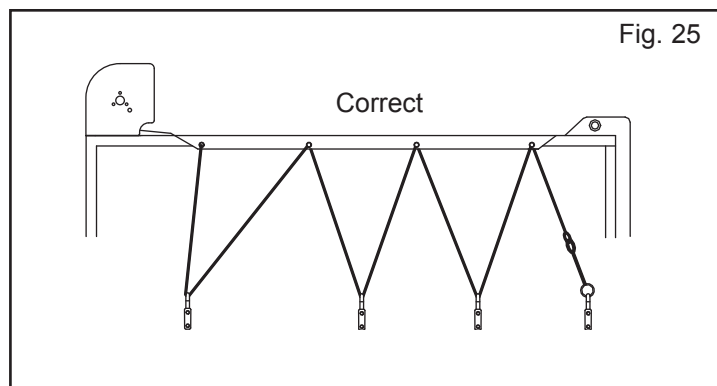
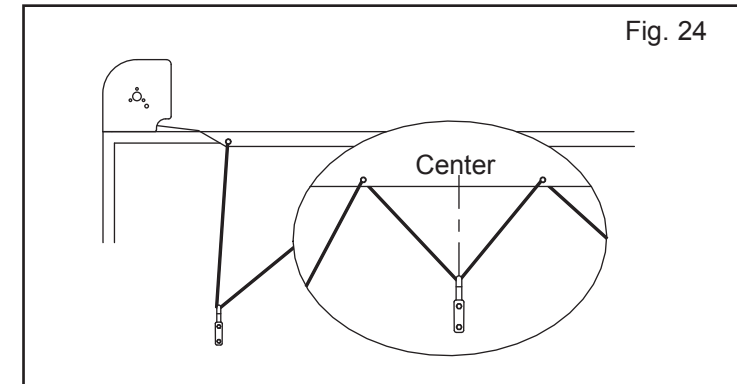
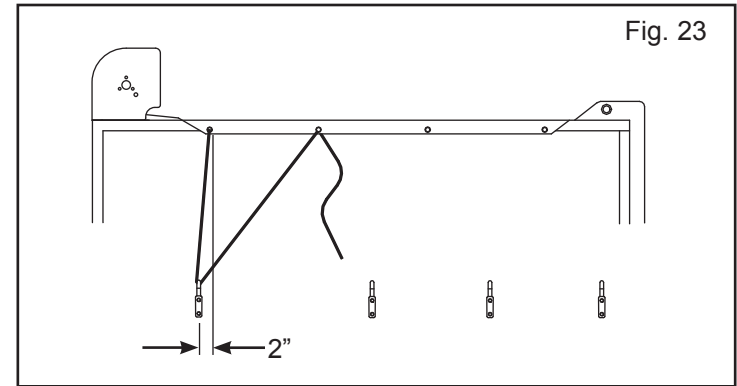

## Step 9. Optional Flap Tarp, Rope and Hook Installation

Parts: Tie Down Hooks (Steel or Alum.)

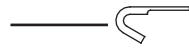

Pull Down Hook



### The Location Of The Tie Down Hooks Is Critical !

Flip the braided rope over the corner so that the flaps and tie down ropes hang over each side of the box. The number of tie down hooks vary depending on the length of your tarp. One pull down hook is included with your Pulltarp system. If needed. Use the hook to pull the braided rope and flap over the side of the box.

#### The tie down hooks must be positioned so that:

- The tie down rope can be reached from the ground.
- The bungee cord has to be stretched to reach the last hook (see step 9).
- The rope has no slack.
- The tie down hooks are level with one another.

To ensure proper hook placement, first duct tape the rope to the box in place of the tie down hooks. Start with hook closest to the cab.

- Position the first hook 6" (15.24cm) down and 12" (30.48cm) forward (toward the cab) from the first grommet (Fig.27).
- Position 2nd hook straight down from 1st grommet. This hook should be reached from ground (Fig.28).
- Place middle hooks equal distances from grommet (Fig.29). These hooks should be placed at the same height as the second hook.
- Position last hook (closest to the tailgate) below the last grommet at the same height as the others (Fig.30).
- Weld hooks in place.

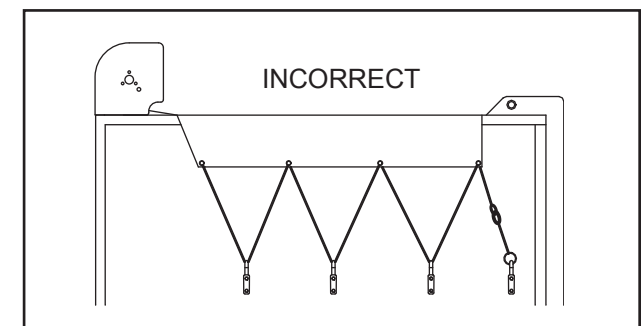
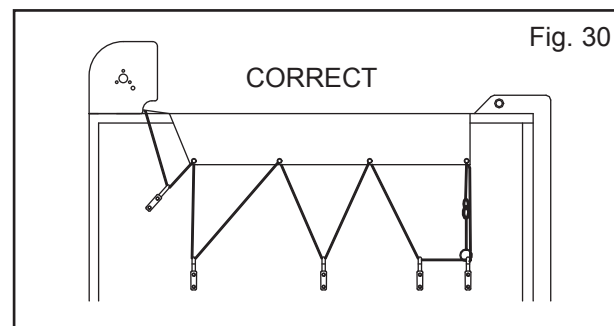
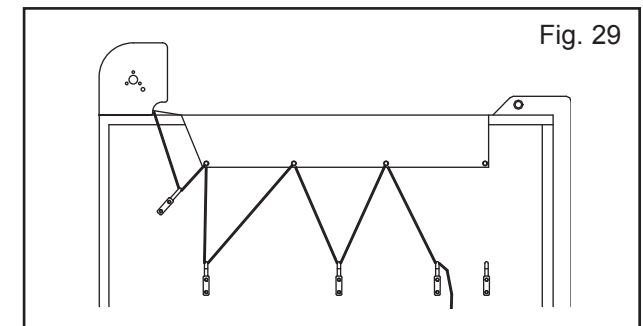
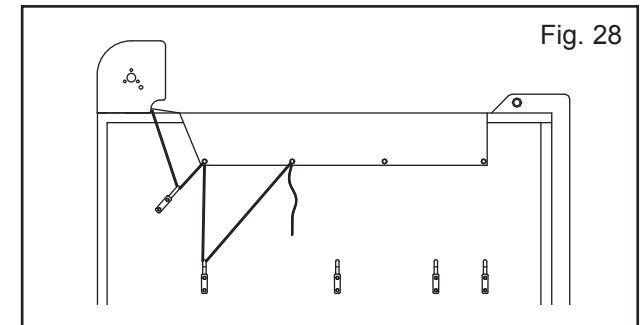
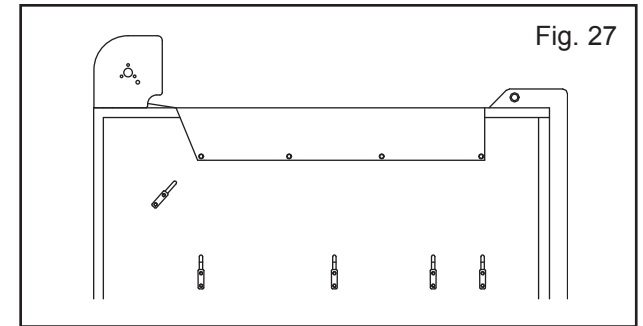



### Step 10. Bungee Cord Installation

After side hooks are installed, the tie down rope must be installed and cut to proper length. It is important to get all of the slack out of the rope to prevent blowing and rubbing of flaps in windy conditions.

**Parts:**

2 Bungee Cords, 

2 Oval Compression sleeves, 

1 Snap Clip 

### Tarps with Tie Downs

To tighten, pull loose end of rope through the Oval Compression Sleeve (Fig.31). Stretch the bungee cord making sure all slack is taken out of the rope, crimp compression sleeve (Fig.32).

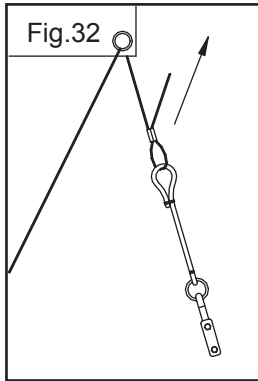
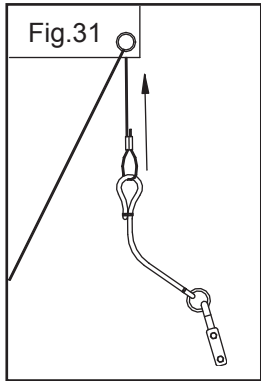

### Snap Clip installation

Flip the rope back on top of the tarp, making sure to hold the bungee at all times. The first snap clip is factory installed 5'-6" from the pullrod. Open the clip and enclose the rope. Weave the second clip through the main pullrope where the ends of the bungee cords meet the main pullrope. Make sure the rope is taught when clipped. *NOTE: First snap clip should not be used on long wheel base belly dumps.*

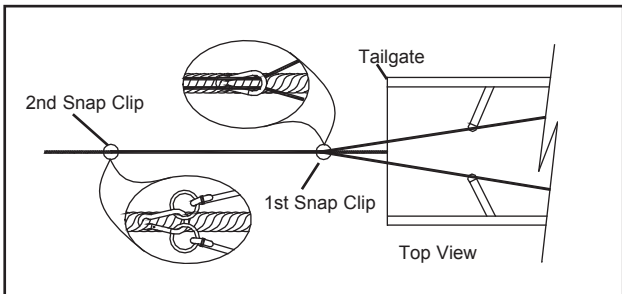

### Connect Bungee Cord to Rope

1. Thread braided rope through Oval Compression Sleeve.
2. Feed rope through the eye of the bungee cord.
3. Thread the rope back through the oval compression sleeve. Adjust for proper length. Crimp compression sleeve.

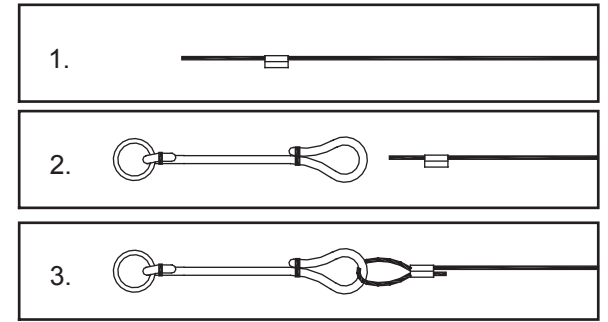

### Tarps with Side Flaps

To tighten, pull loose end of rope through the Oval Compression Sleeve (Fig.33). Stretch the bungee cord making sure all slack is taken out of the rope, crimp compression sleeve (Fig.34).

**Note:** Check for proper placement of rope through the last two hooks.

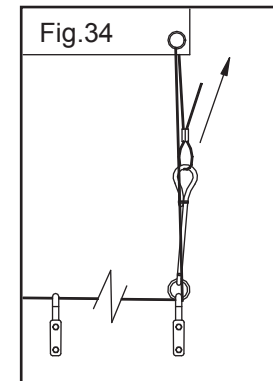
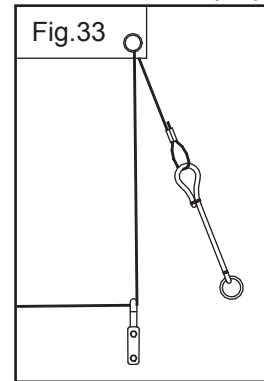

### Excess Rope

You may need extra rope to keep the side flap system ground operated. If your application requires extra rope, the slack needs to be taken up by attaching the end of the bungee cord to an alternate hook. (pictured below)

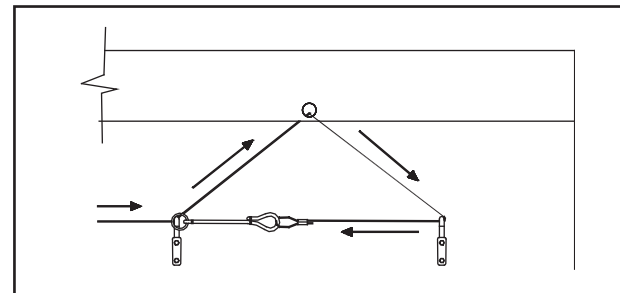

## Step 11. How to change the system to roll off the top

### \*\*\*WARNING\*\*\*

*YOU MUST RELEASE THE SPRING PRESSURE / PRELOAD  
BEFORE TRYING TO DISASSEMBLE THE SYSTEM*

*(See page 6 removing the tarp and releasing the spring preload)*

The system is designed with the slotted end plate to the right (passenger) side. Remove the Universal End Plate Stud, by taking the three bolts and washers off. Next go to the driver side end plate and remove the Steel Spring Shaft Anchor, by removing the three bolts and washers. Remount the Steel Spring Shaft Anchor to the passenger side end plate. Insert the Universal End Plate Stud to the roller assembly and then bolt to the driver side end plate. If you ordered the system to roll off the top, your system would be assembled with these changes already done for you.

**Note:** The roller should be free to move from side to side at least 1/8" and have at least one nylon washer per side.

### Bottom Roll System

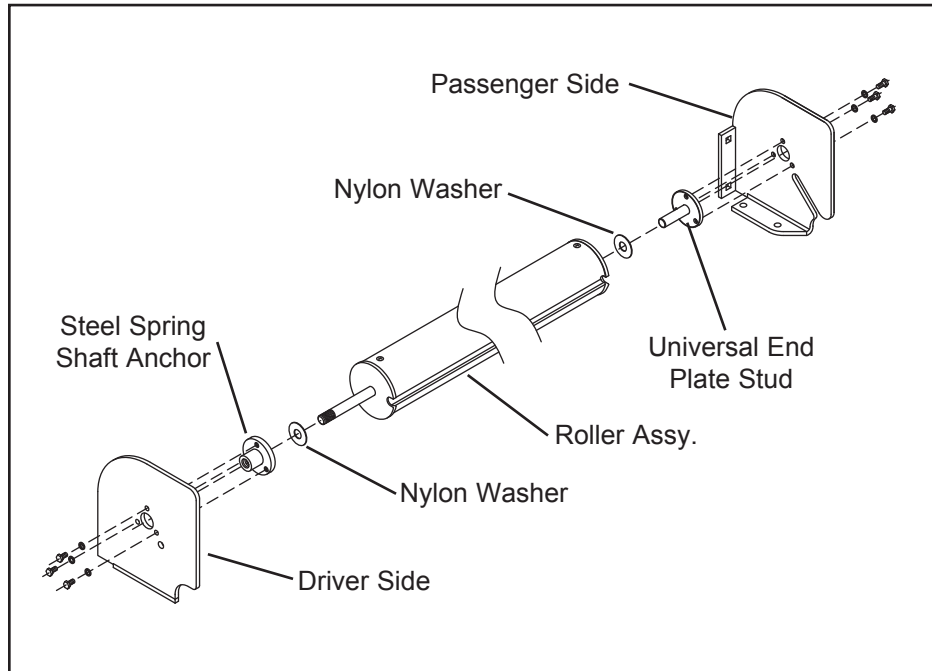

### Top Roll System

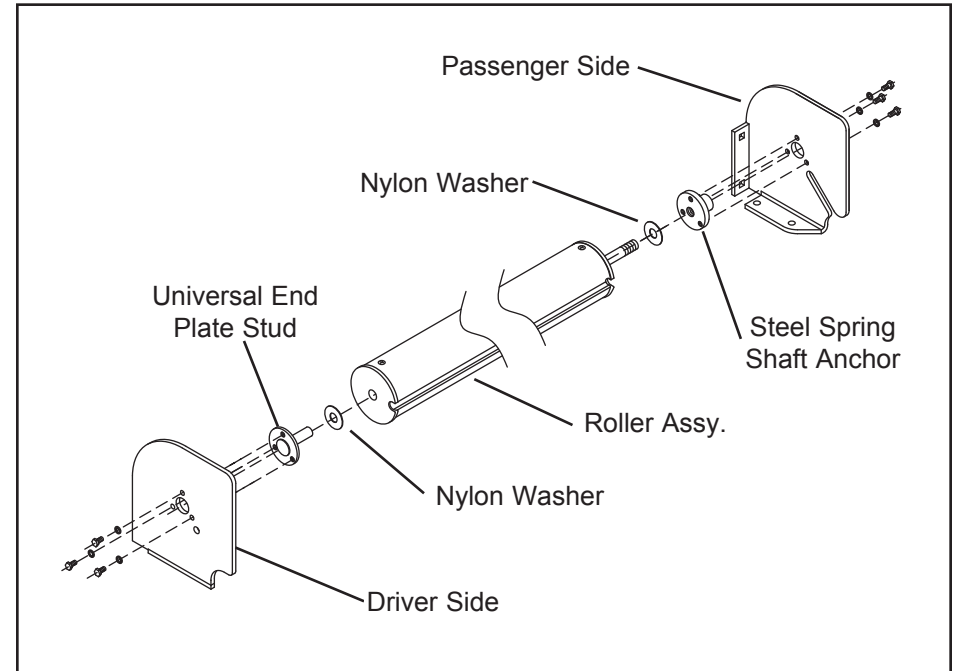

**Preload the Spring Mechanism**

Refer to page 6

# 7" ALUMINUM OPEN SYSTEM (#102-0215 WIDTHS OF 80,84,87,89,93,96,100")

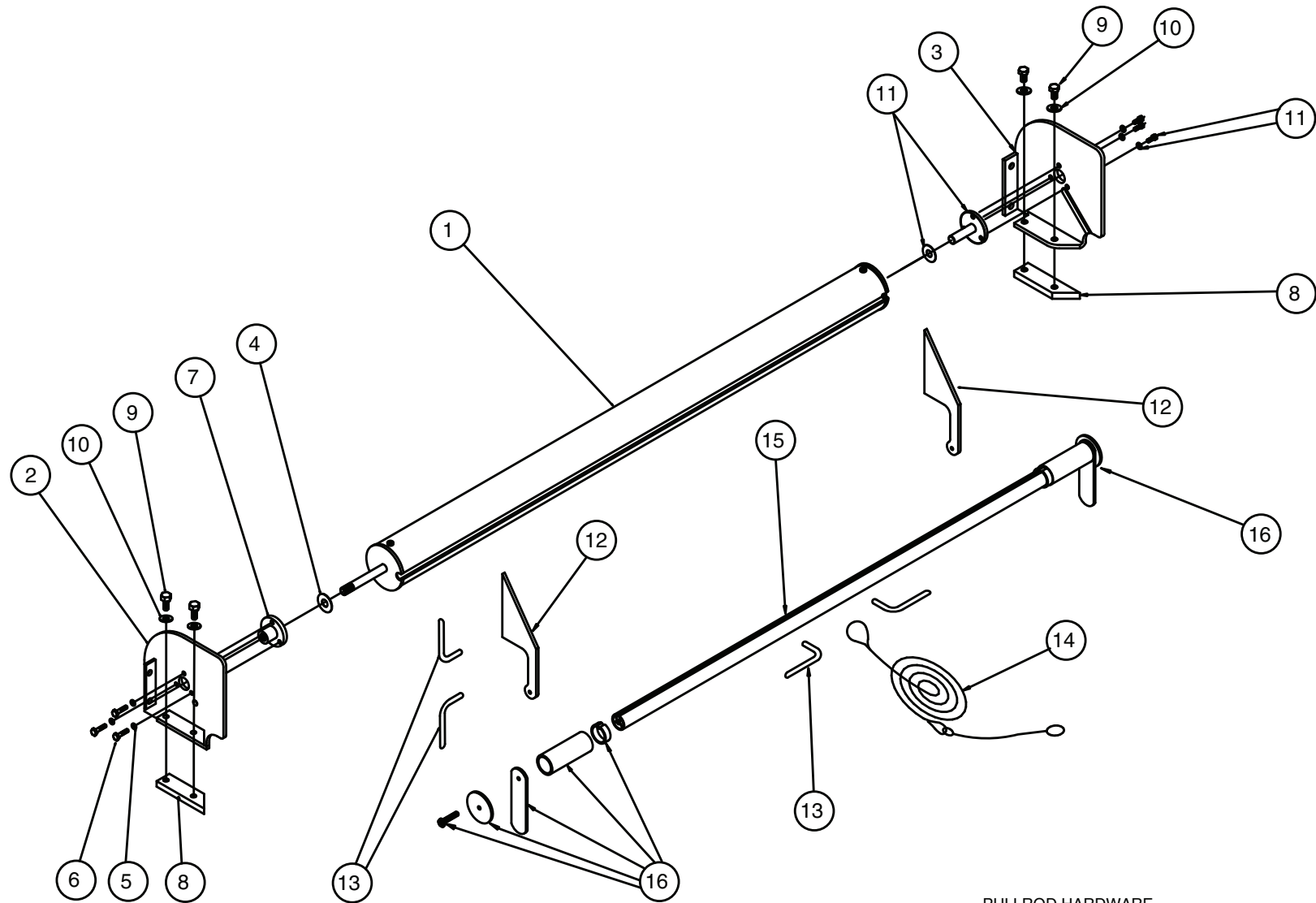

ITEM	PART#	DESCRIPTION	QTY
1	501-13XX	ROLLER ASSEMBLY, 80,84,87,89,93,96,100"	1
2	501-0207	7.5" FOLDED ALUM. END PLATE-DRVR.	1
3	501-0208	7.5" FOLDED ALUM. END PLATE-PASS.	1
4	505-5002	NYLON WASHER	1
5	505-2503	1/4" LOCK WASHER	3
6	503-2503	1/4"-20 x 1/2"lg. HHCS BOLT	3
7	501-0804	STEEL SPRING SHAFT ANCHOR	1
8	501-1504	5" MOUNTING BAR	2
9	503-3102	5/16"-18 x 5/8"lg. HHCS BOLT	4
10	505-3102	5/16" LOCK WASHER	4
11	501-0633	UNIVERSAL BOLT IN STUD KIT	1

## PULLROD HARDWARE

ITEM	PART#	DESCRIPTION	QTY
12	501-0301	TARP RETURN RAMPS (STEEL)	2
	501-0302	TARP RETURN RAMPS (ALUM.)	2
13	501-0621	ROPE STORAGE KIT (4 STEEL HOOKS)	1
	501-0608	ROPE STORAGE KIT (4 ALUM. HOOKS)	1
14	517-10XX	PULL ROPE 20,25,30,35,40,50'	1
15	DETERMINED BY LENGTH	PULLROD (85,91,93,96,100,105" LENGTHS)	1
16	501-0612	PULL ROD HARDWARE KIT	1

REV: 11/7/07 BAB

# 7" OPEN SYSTEM W/WIND GUARD

(#103-0215 WIDTHS OF 80,84,87,89,93,96,100")

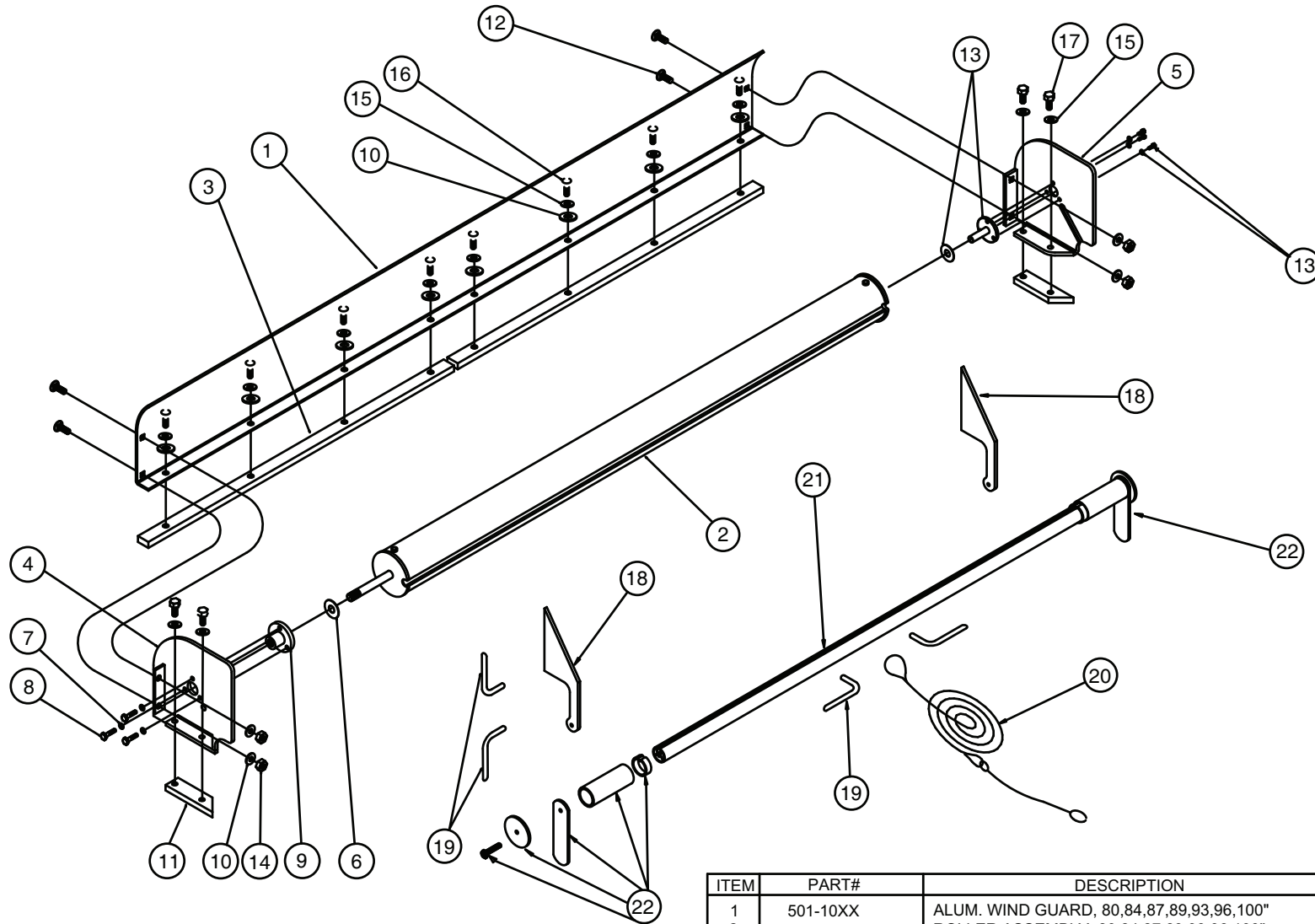

### PULL ROD HARDWARE

ITEM	PART#	DESCRIPTION	QTY
17	501-3102	5/16"-18 x LG. HHCS BOLT	4
18	501-0301	TARP RETURN RAMPS (STEEL)	2
	501-0302	TARP RETURN RAMPS (ALUM.)	2
19	501-0621	ROPE STORAGE KIT (4 STEEL HOOKS)	1
	501-0608	ROPE STORAGE KIT (4 ALUM. HOOKS)	1
20	517-10XX	PULL ROPE 20,25,30,35,40,50'	1
21	DETERMINED BY LENGTH	PULLROD (85,91,93,96,100,105" LENGTHS)	1
22	501-0612	PULL ROD HARDWARE KIT	1

REV: 12/15/11 NB

ITEM	PART#	DESCRIPTION	QTY
1	501-10XX	ALUM. WIND GUARD, 80,84,87,89,93,96,100"	1
2	501-13XX	ROLLER ASSEMBLY, 80,84,87,89,93,96,100"	1
3	501-15XX	MOUNTING BAR-STEEL, 40,42,43.5,44.5,46.5,48,50"	2
4	501-0207	7.5" ALUMINUM END PLATE (DRVR.)	1
5	501-0208	7.5" ALUMINUM END PLATE (PASS.)	1
6	505-5002	NYLON WASHER	1
7	505-2503	1/4" LOCK WASHER	3
8	503-2503	1/4"-20 X 1/2"lg. HHCS BOLT	3
9	501-0804	STEEL SPRING SHAFT ANCHOR	1
10	505-2502	1/4" FLAT WASHER USS	12
11	501-1504	5" STEEL MOUNTING BAR	2
12	503-3104	5/16"-18 x 3/4"lg. CARRIAGE BOLT	4
13	501-0633	UNIVERSAL BOLT IN STUD KIT	1
14	504-3103	5/16"-18 NYLOC NUT	4
15	505-3102	5/16" LOCK WASHER	12
16	503-3101	5/16"-18 x 1/2"lg. HHCS BOLT	8