

Installation Instructions - Electric Aluminum Drive Systems for Arm Sets to 22'

Electric Arm Systems - 204-0215, 206-0215, 221-0215

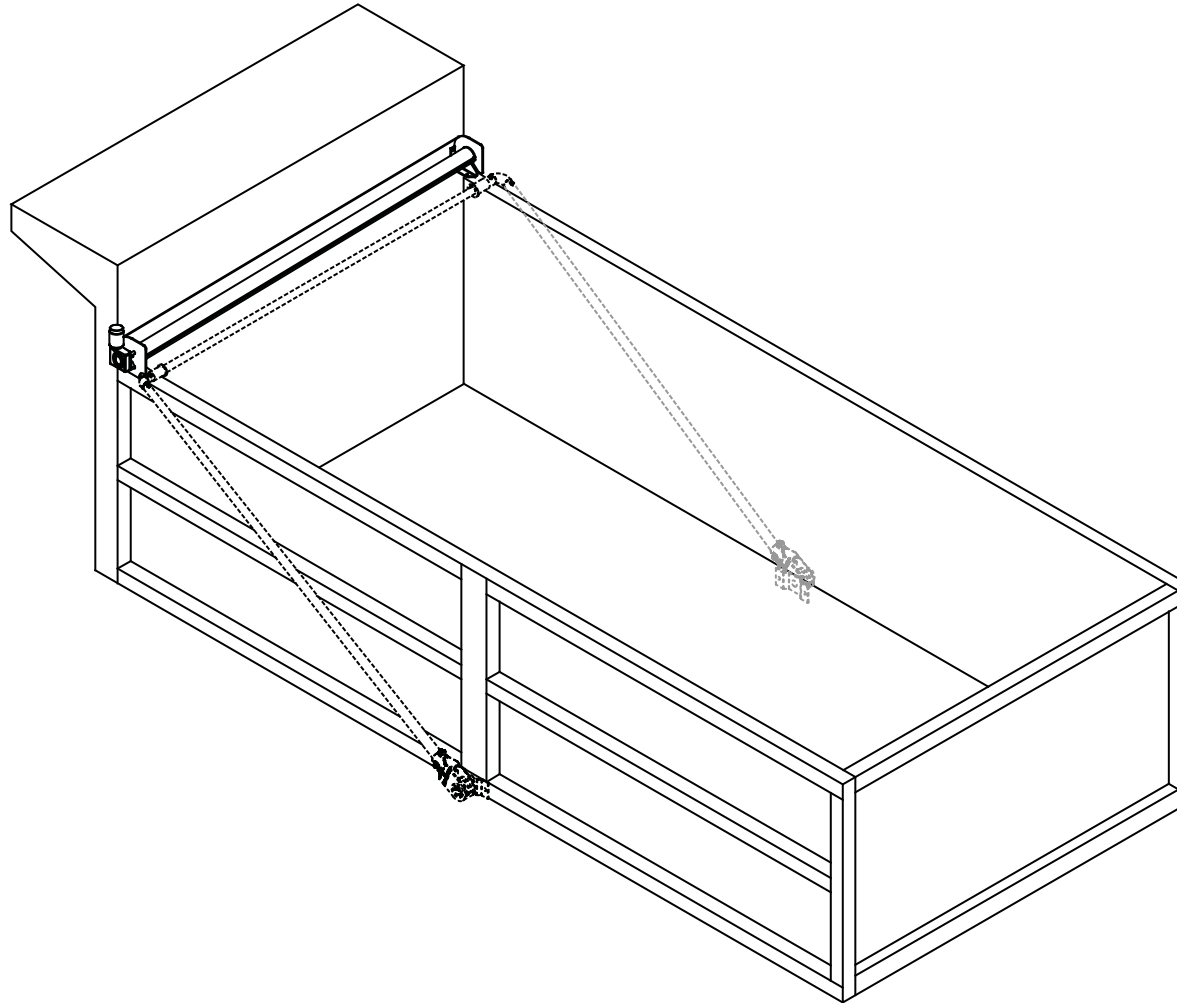

Step 1. Mounting Positions

Determine the mounting position for your truck Fig. 1 - Fig. 7.

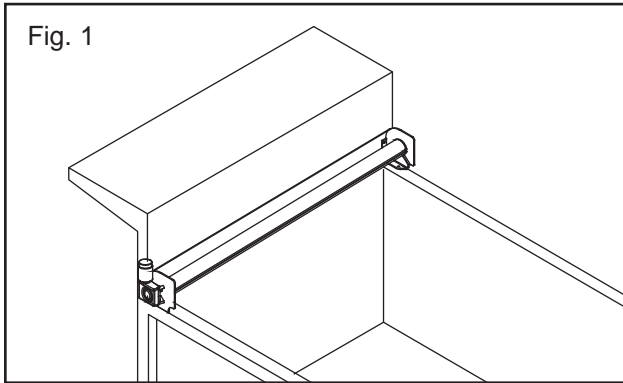

"A" Mount

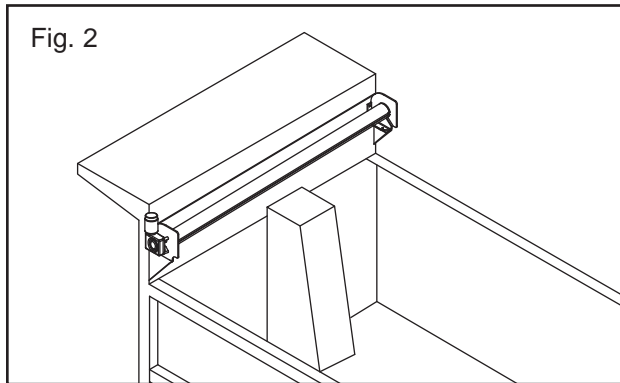

"B" Mount

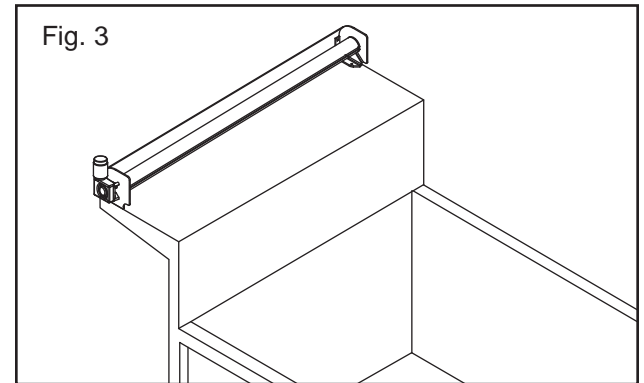

"C" Mount

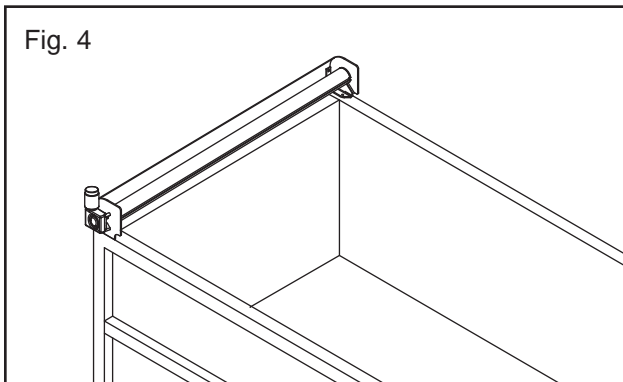

"D" Mount

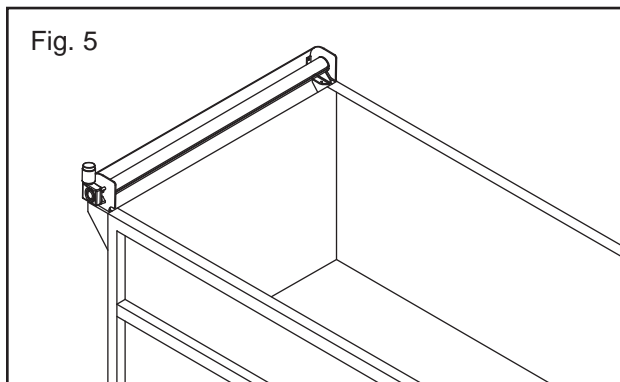

"E" Mount

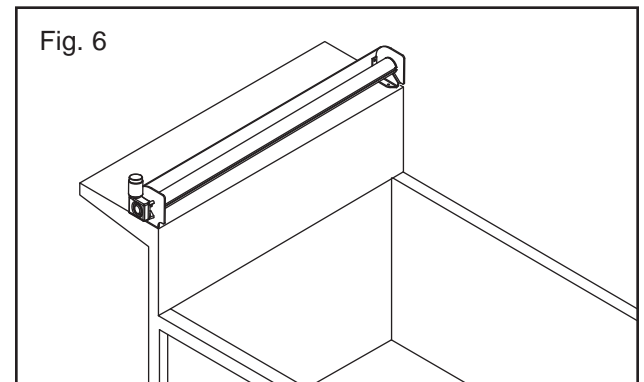

"F" Mount

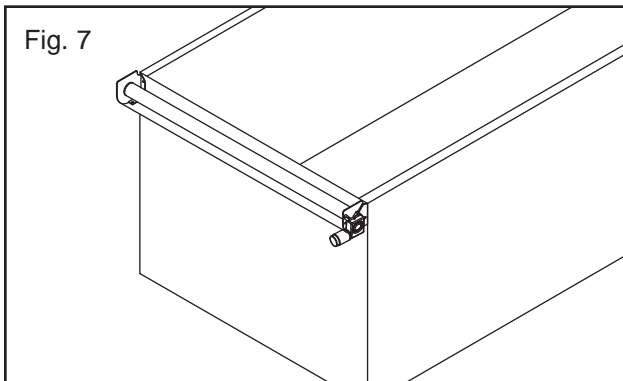

"G" Mount

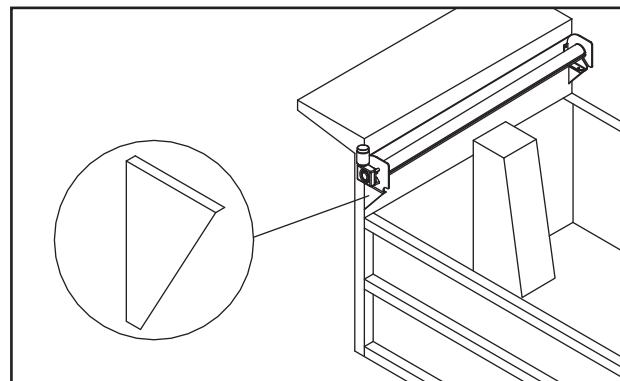

NOTE: Use optional "B" Brackets when mounting in position "B" and "E".

System Assembly Fig. 8A, 8B

Fig. 8A

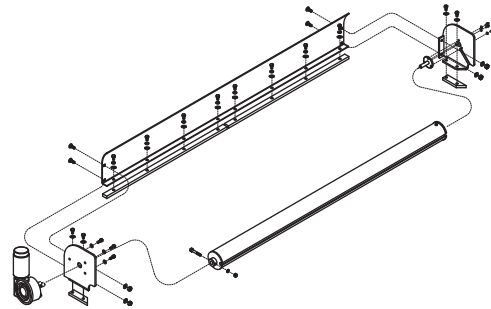

Aluminum System
204-0215, 206-0215

Step 2A. Weld System To Truck

Weld system mounting bar to truck as shown in Fig. 9.

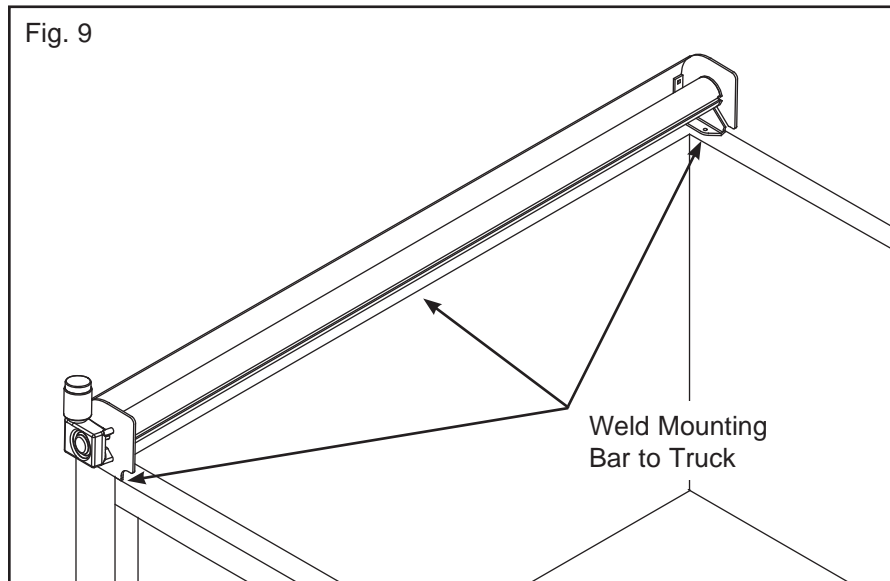

Step 2B. Tarp Installation

Slide Tarp into groove on Roller Tube and center (Fig. 10).

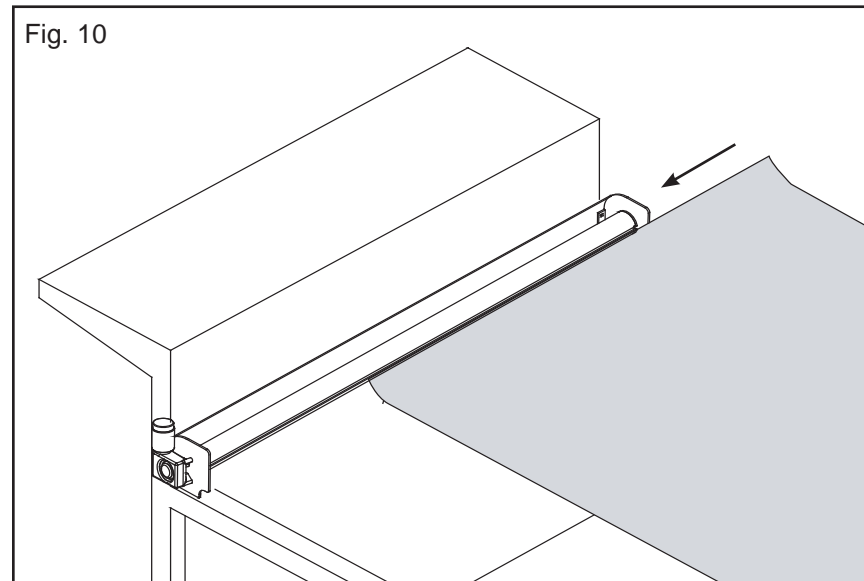

NOTE: See Switch Kit for Wiring Instructions.

Step 3. Optional Tie Down Tarp, Rope and Hook Installation

Parts: Tie Down Hooks (Steel or Alum.)

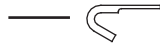

Pull Down Hook



The Location Of The Tie Down Hooks Is Critical!

Flip the braided rope over the corner so that the rope and tie down flap hang over each side of the box. The number of tie down hooks vary depending on the length of your tarp. One pull down hook is included with your Pulltarp system. If needed. Use the hook to pull the braided rope and tie down flap over the side of the box.

The tie down hooks must be positioned so that:

- The tie down rope can be reached from the ground.
- The bungee cord has to be stretched to reach the last hook (see step 5).
- The rope has no slack.
- The tie down hooks are level with one another.

To ensure proper hook placement, first duct tape the rope to the box in place of the tie down hooks. Start with hook closest to the cab.

- Position the first hook 2" (5.08cm) forward of first tie down (Fig.11).
- Position middle hook between tie downs (Fig.12).
- Position last hook at the end of the box (Fig.13).
- Weld hooks in place level with one another.

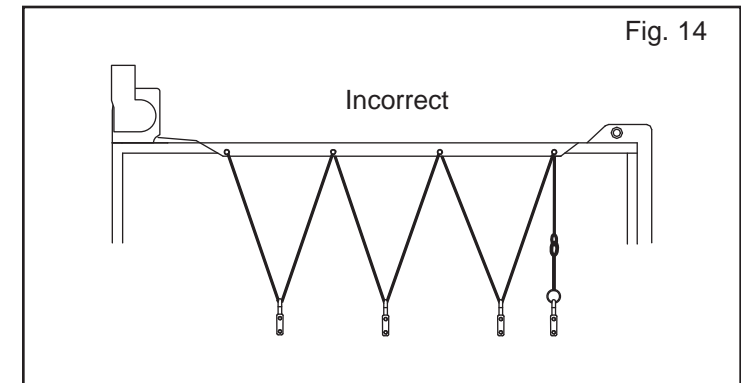
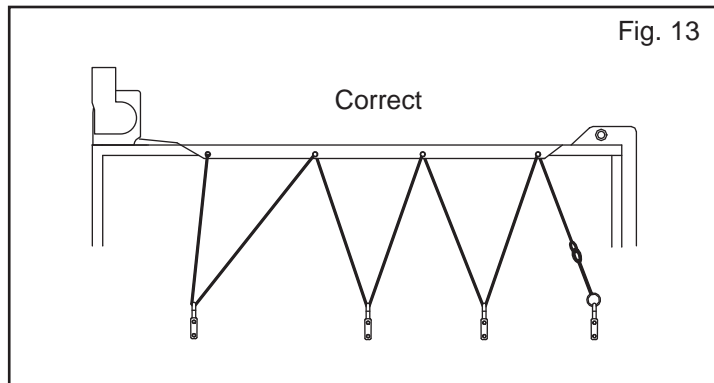
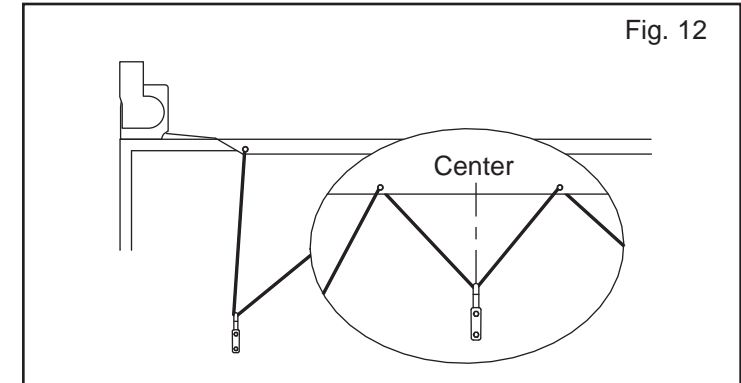
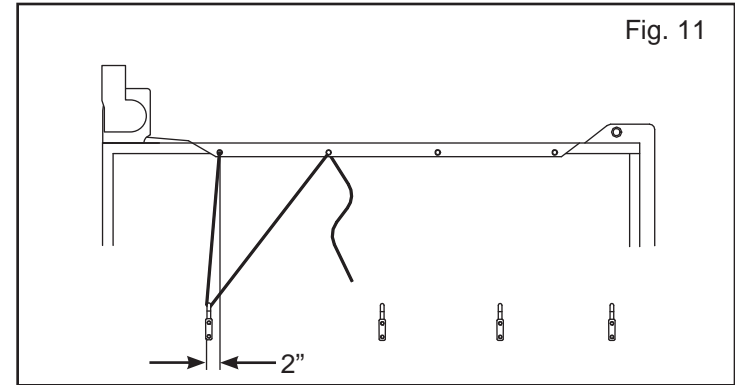

Step 4. Optional Flap Tarp, Rope and Hook Installation

Parts: Tie Down Hooks (Steel or Alum.) 

Pull Down Hook 

The Location Of The Tie Down Hooks Is Critical!

Flip the braided rope over the corner so that the flaps and tie down ropes hang over each side of the box. The number of tie down hooks vary depending on the length of your tarp. One pull down hook is included with your Pulltarp system. If needed. Use the hook to pull the braided rope and flaps over the side of the box.

The tie down hooks must be positioned so that:

- The tie down rope can be reached from the ground.
- The bungee cord has to be stretched to reach the last hook (see step 5).
- The rope has no slack.
- The tie down hooks are level with one another.

To ensure proper hook placement, first duct tape the rope to the box in place of the tie down hooks. Start with hook closest to the cab.

- Position the first hook 6" (15.24cm) down and 12" (30.48cm) forward (toward the cab) from the first grommet (Fig.15).
- Position 2nd hook straight down from 1st grommet. This hook should be reached from ground (Fig.16).
- Place middle hooks equal distances from grommet (Fig.17). These hooks should be placed at the same height as the second hook.
- Position last hook (closest to the tailgate) below the last grommet at the same height as the others (Fig.18).
- Weld hooks in place.

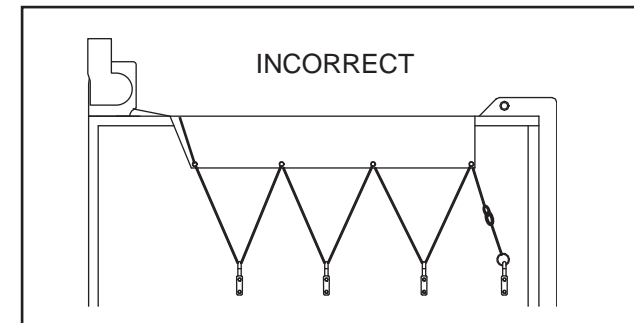
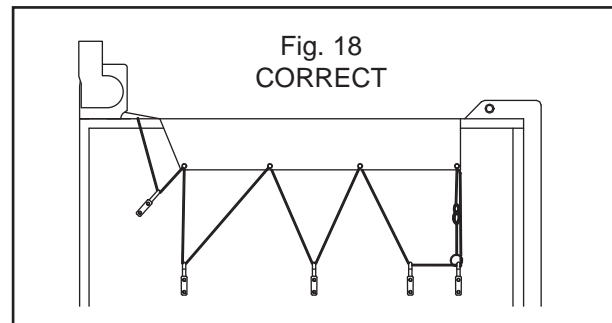
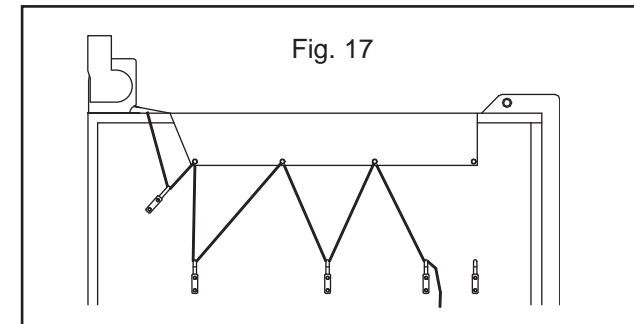
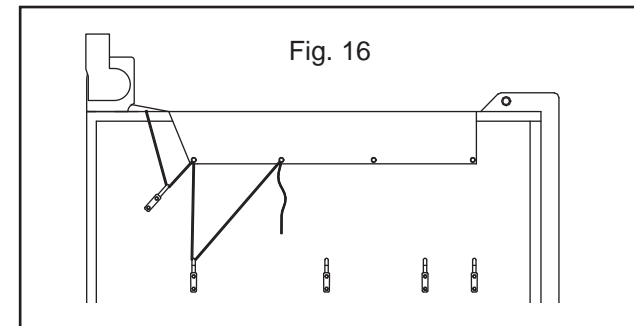
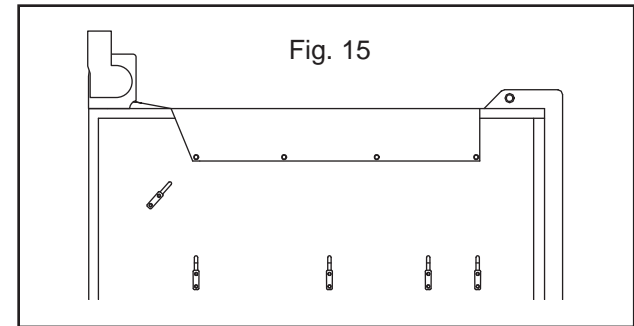

Step 5. Bungee Cord Installation

After side hooks are installed, the tie down rope must be installed and cut to proper length. It is important to get all of the slack out of the rope to prevent blowing and rubbing of flaps in windy conditions.

Parts:

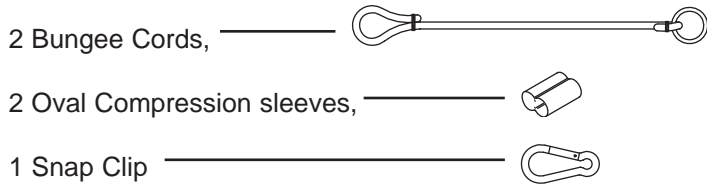

Tarps with Tie Downs

To tighten, pull loose end of rope through the Oval Compression Sleeve (Fig.19). Stretch the bungee cord making sure all slack is taken out of the rope, crimp compression sleeve (Fig.20).

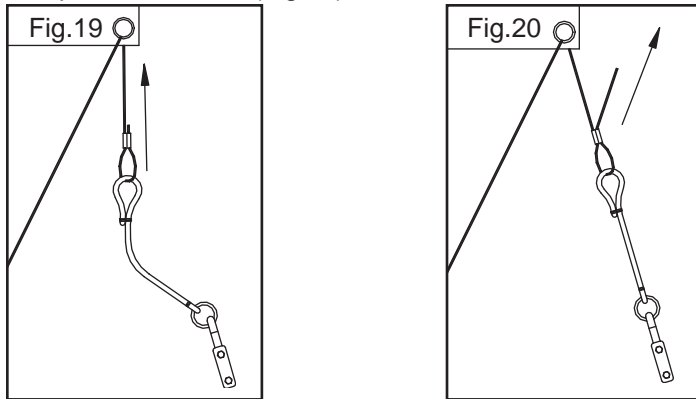

Snap Clip installation

Flip the rope back on top of the tarp, making sure to hold the bungee at all times. The first snap clip is factory installed 5'-6" from the pullrod. Open the clip and enclose the rope. Weave the second clip through the main pullrope where the ends of the bungee cords meet the main pullrope. Make sure the rope is taught when clipped. *NOTE: First snap clip should not be used on long wheel base belly dumps.*

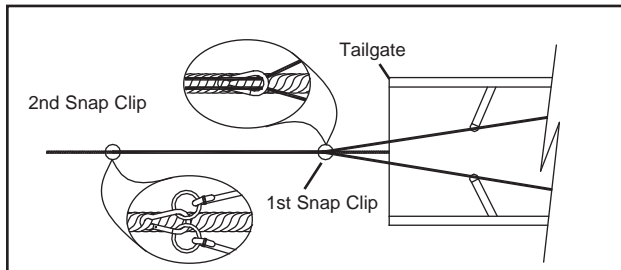

Connect Bungee Cord to Rope

1. Thread braided rope through Oval Compression Sleeve.
2. Feed rope through the eye of the bungee cord.
3. Thread the rope back through the oval compression sleeve. Adjust for proper length. Crimp compression sleeve.

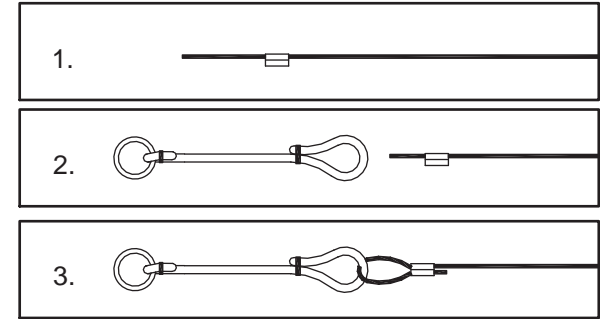

Tarps with Side Flaps

To tighten, pull loose end of rope through the Oval Compression Sleeve (Fig.21). Stretch the bungee cord making sure all slack is taken out of the rope, crimp compression sleeve (Fig.22).

Note: Check for proper placement of rope through the last two hooks.

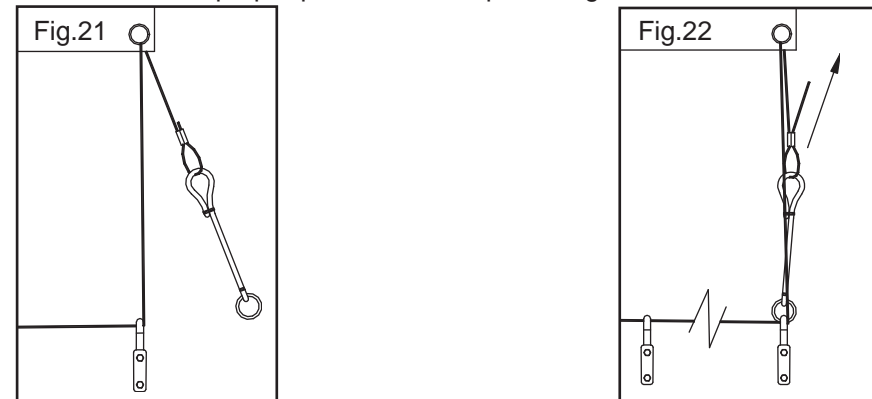

Excess Rope

You may need extra rope to keep the side flap system ground operated. If your application requires extra rope, the slack needs to be taken up by attaching the end of the bungee cord to an alternate hook. (pictured below)

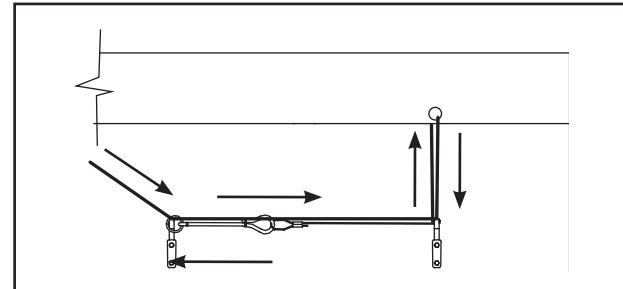

Step 6. Flap / Tie Down Rope Placement and Installation (Fig. 23).

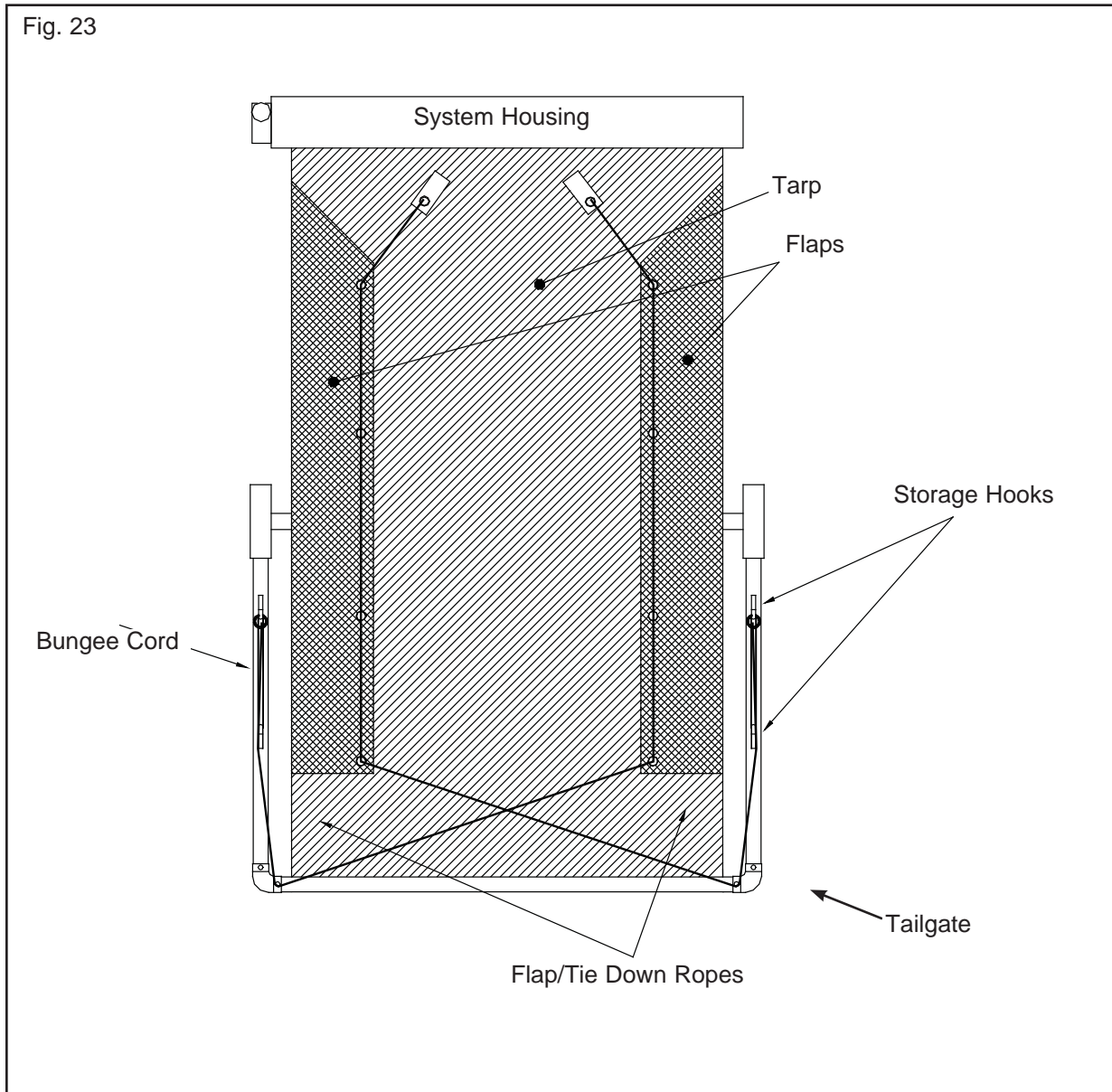

Step 7. Rope Hook Placement For Steel Arms
Weld rope storage hook on the top of the arms approx. 32" apart (Fig. 24 A)

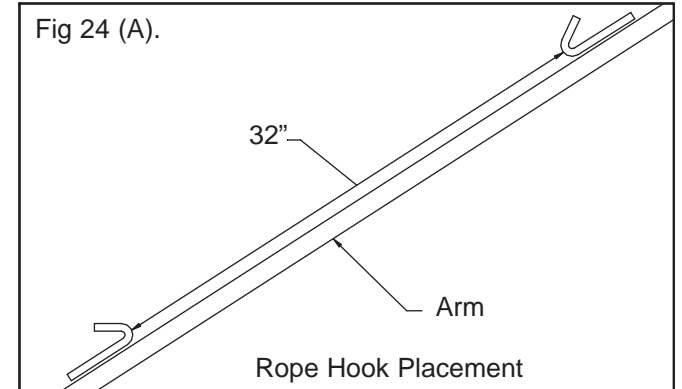

Step 7. Rope Hook Placement for Aluminum Arms
Use Self Drilling screws (part #506-9933) to install Hooks (Fig. 24 B)

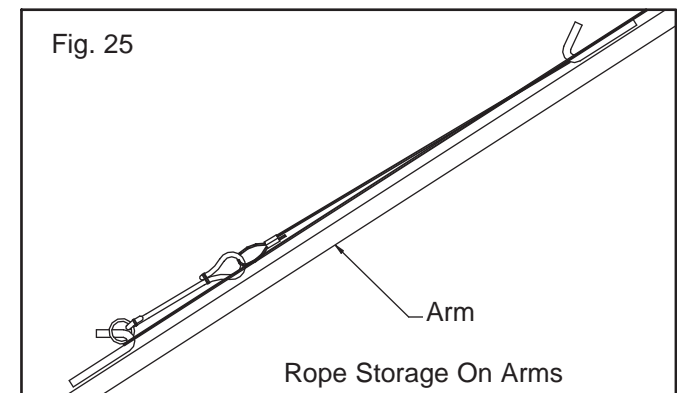
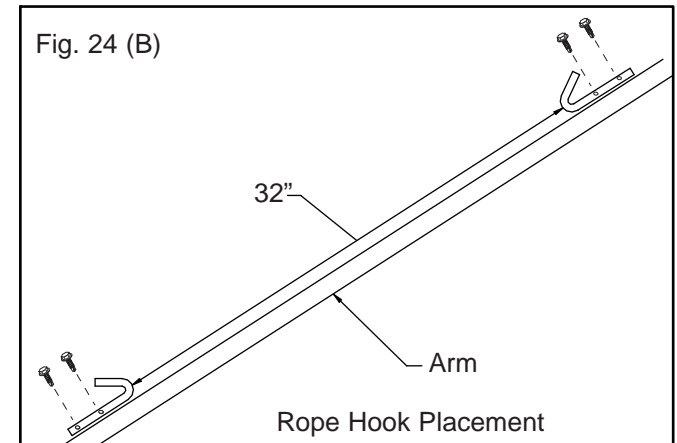

Option #1. Plug Assembly - Part # 514-0505

Assemble the Quick Disconnect as shown in Fig. 26 and Fig. 27.

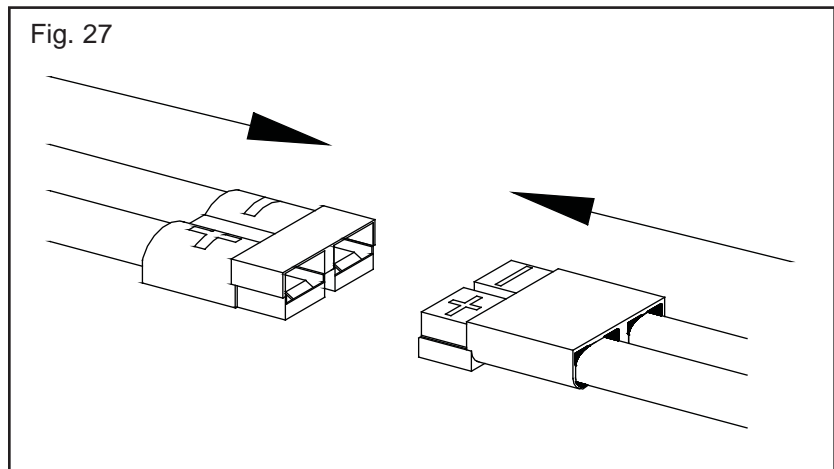
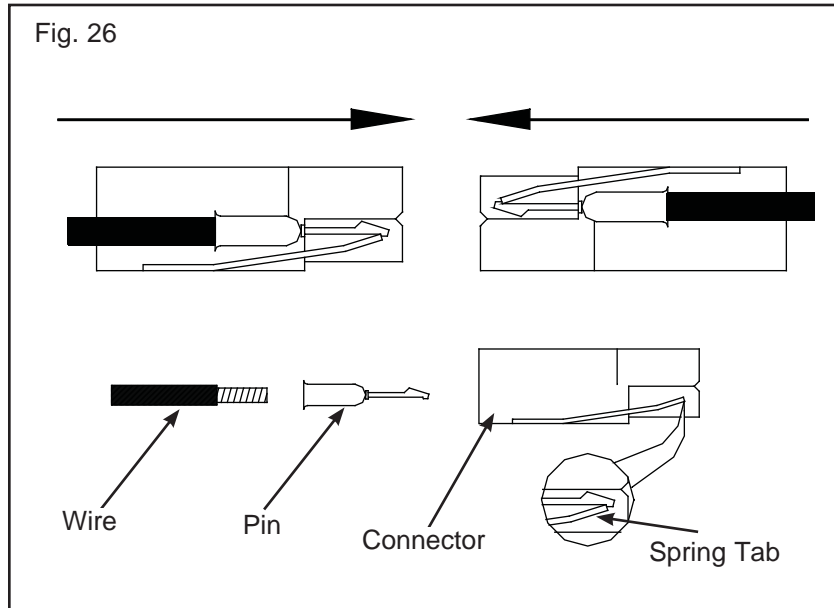

Option #2. Plug Assembly - Part # 514-0501

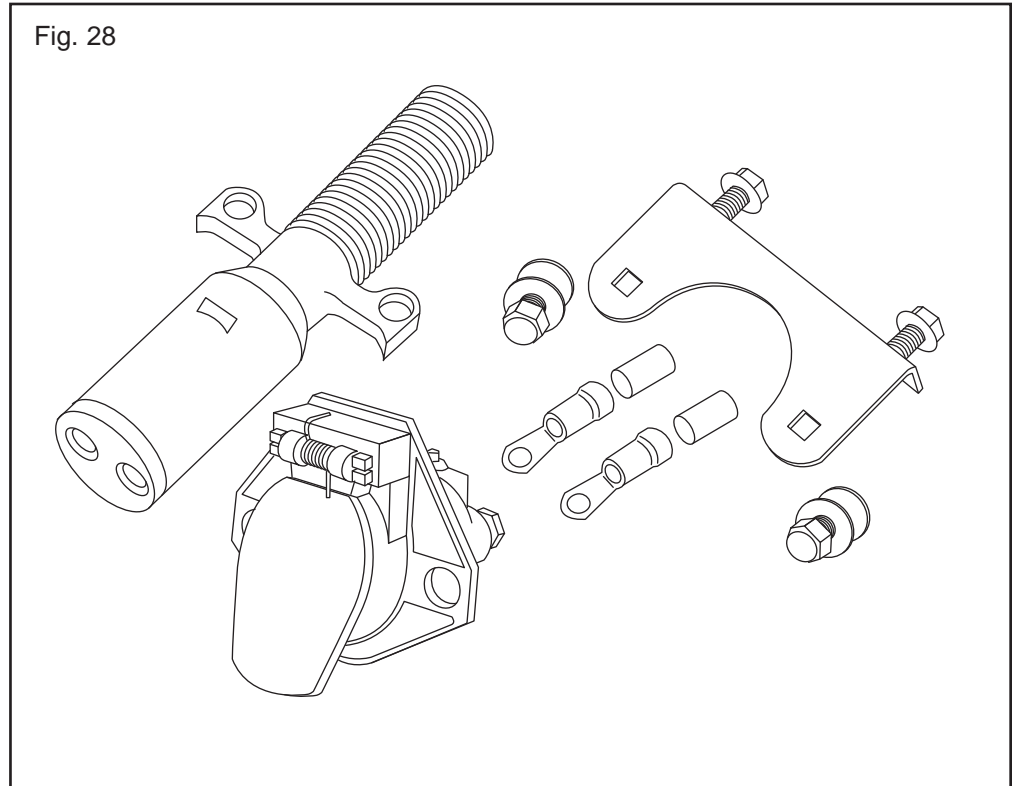

7" ALUMINUM ELECTRIC ARM SYSTEM # 204-0215, 206-0215

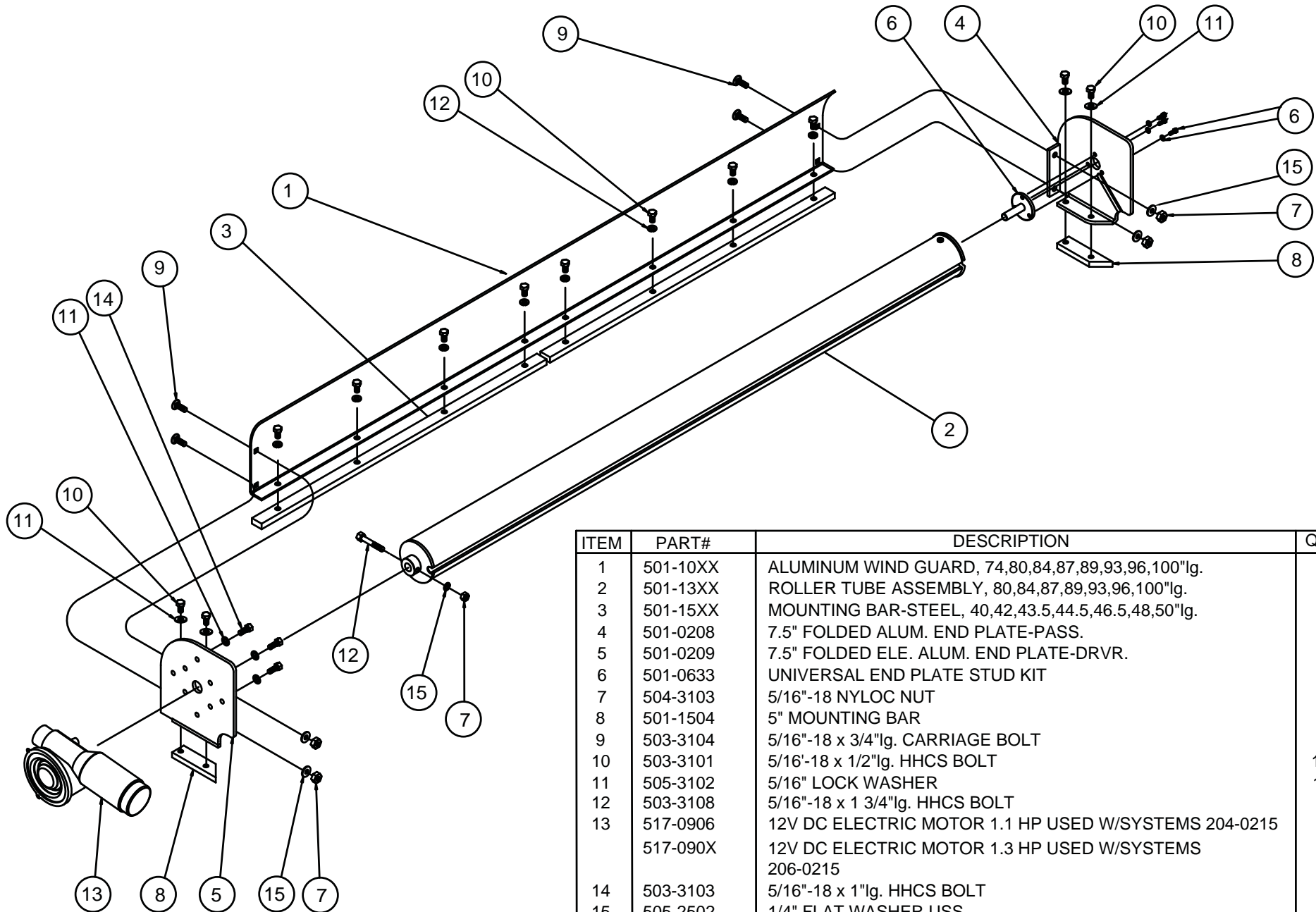

ITEM	PART#	DESCRIPTION	QTY
1	501-10XX	ALUMINUM WIND GUARD, 74,80,84,87,89,93,96,100"lg.	1
2	501-13XX	ROLLER TUBE ASSEMBLY, 80,84,87,89,93,96,100"lg.	1
3	501-15XX	MOUNTING BAR-STEEL, 40,42,43.5,44.5,46.5,48,50"lg.	2
4	501-0208	7.5" FOLDED ALUM. END PLATE-PASS.	1
5	501-0209	7.5" FOLDED ELE. ALUM. END PLATE-DRVR.	1
6	501-0633	UNIVERSAL END PLATE STUD KIT	1
7	504-3103	5/16"-18 NYLOC NUT	5
8	501-1504	5" MOUNTING BAR	2
9	503-3104	5/16"-18 x 3/4"lg. CARRIAGE BOLT	4
10	503-3101	5/16"-18 x 1/2"lg. HHCS BOLT	13
11	505-3102	5/16" LOCK WASHER	15
12	503-3108	5/16"-18 x 1 3/4"lg. HHCS BOLT	1
13	517-0906	12V DC ELECTRIC MOTOR 1.1 HP USED W/SYSTEMS 204-0215	1
	517-090X	12V DC ELECTRIC MOTOR 1.3 HP USED W/SYSTEMS 206-0215	
14	503-3103	5/16"-18 x 1"lg. HHCS BOLT	3
15	505-2502	1/4" FLAT WASHER USS	4

REV: 02/22/08 KJH