

OPTIONAL LOAD CLIMBER

(#501-0901)

ITEM	PART#	DESCRIPTION	QTY
1	505-2502	1/4" FLAT WASHER USS	2
2	503-7501	3/4"-10 x 1"lg. HHCS BOLT	2
3	504-2503	1/4"-20 NYLOC NUT	2
4	501-0905	LOAD CLIMBER ANGLE	1
5	503-2514	1/4"-20 x 2 1/4"lg. HHCS BOLT	2
6	501-0902	LOAD CLIMBER ROD 32' lg. 7/8" DIA.	1
7	501-0909	LOAD CLIMBER 1" PVC 1 1/4" OD.	1
8	501-0903	LOAD CLIMBER SWIVEL ARM 5"	2
9	501-0912	STRAP FOR LOAD CLIMBER	1
10	501-0910	14 3/4"lg. ROLLER ASSY.	2

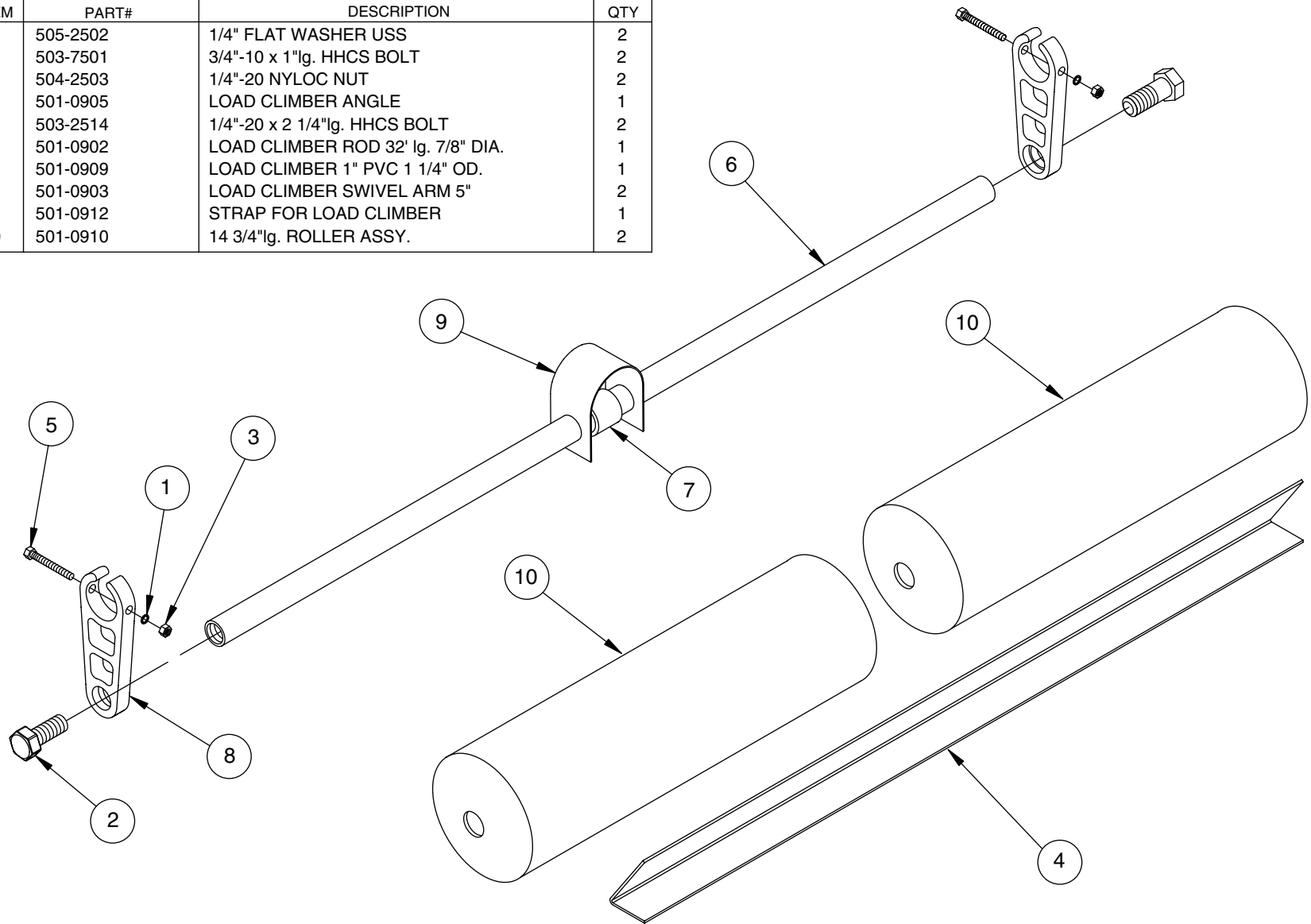

Optional Load Climber Instructions

1. Slide the Load Climber Swivel Arm with Load Climber Rod attached on to Pullrod.
2. Slide Rollers on to the Load Climber Rod with the Load Climber Strap and Load Climber 1" PVC spacer in between as illustrated below.
3. Attach the Load Climber Swivel Arm to the Load Climber Rod using the 3/4" x 1" bolt provided.

Hand tighten only at this time!

4. Using the pre-drilled holes in the Pullrod, secure the Load Climber Swivel Arms in place using the 1/4" x 2-1/4" bolts provided. Start the bolts from the back (tailgate side).

CONTINUED ON NEXT PAGE

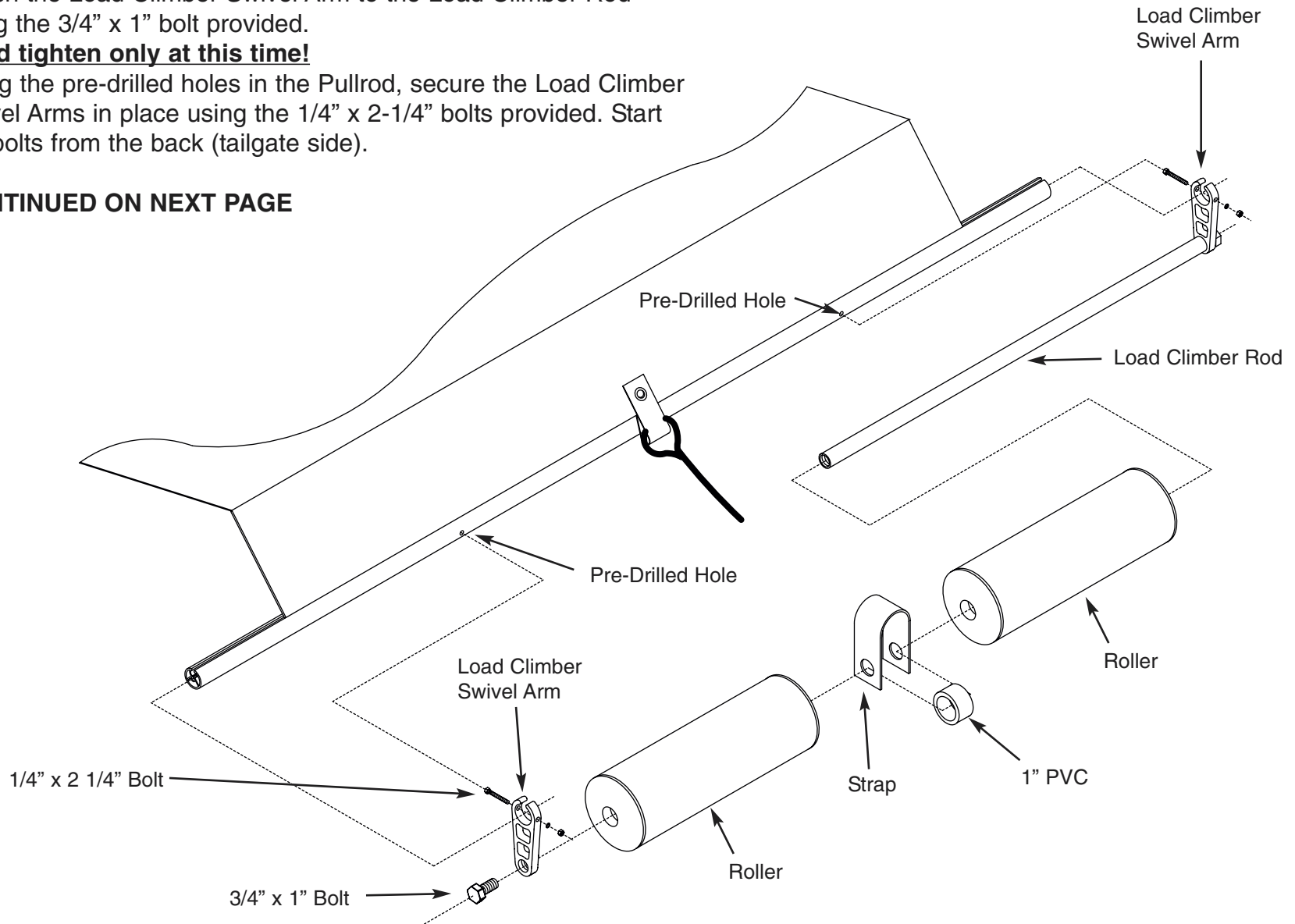

*** SPECIAL INSTRUCTIONS FOR RETRO-FITTING IN THE FIELD ***

- A) Using the Load Climber Swivel Arm as guide, drill the Pullrod halfway through from each side
NOTE: Do not drill through the Pullrod in one pass. The hole must meet in the center so the attaching bolts will pass through the Load Climber Swivel Arm and Pullrod (Fig.1).
- B) Secure the Load Climber Swivel Arm in place using the 1/4" x 2-1/4" bolts. Start the bolts from the back(Tailgate side).

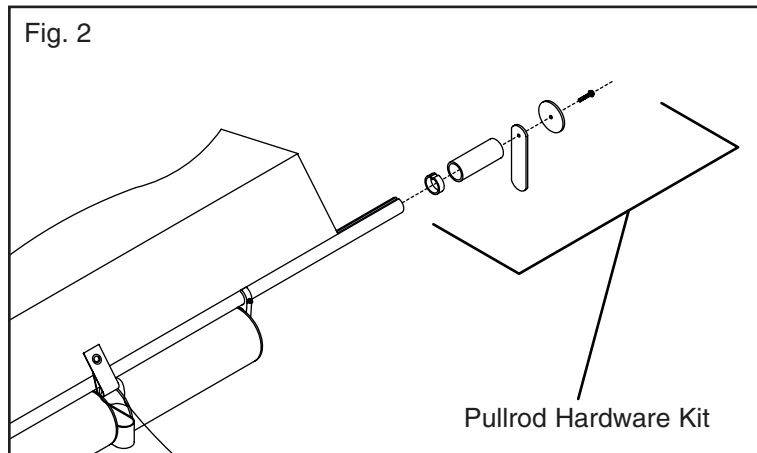
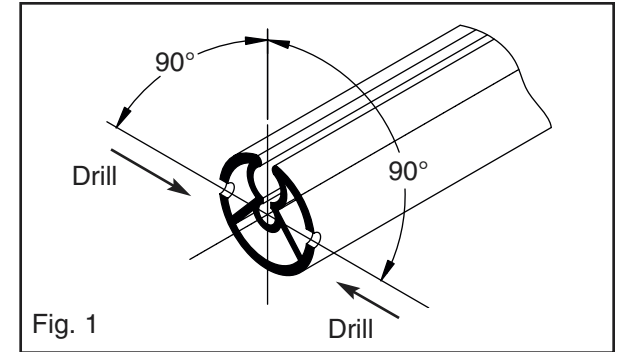

5. Tighten 3/4" x 1" Bolts on each end of the Load Climber Rod at this time, making sure that rod remains parallel with the Pullrod.
6. Attach the Pullrod Hardware Kit to both ends of the Pullrod as illustrated (Fig.2).

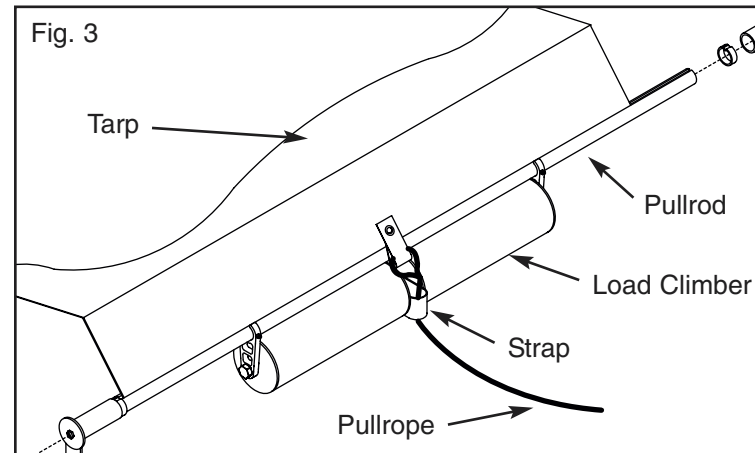

7. The Pullrope should operate from the Tarp at the Pullrod and pass over the Load Climber and through the Strap as shown in (fig.3).

8. Weld the Load Climber Angle to the tailgate in order for the Load Climber to clear the tailgate (Fig.4).

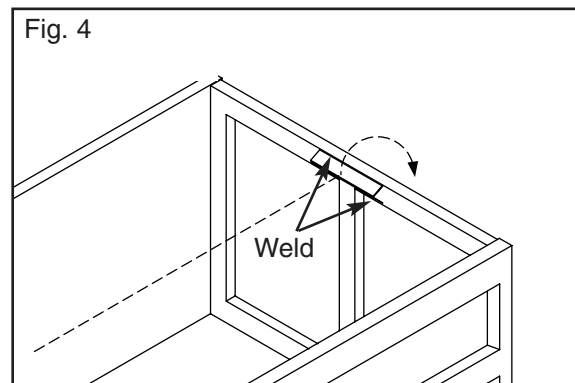

Any Questions? Call our toll free assistance line (800) 368-3075

Thank you for choosing Pulltarps!