

# Spring Shaft Fix Kit with Spring Shaft Anchor

1. Remove entire roller assembly from housing.
2. Remove retaining screw from end cap on roller tube (Fig. 4)
3. Place a piece of cardboard on ground and hold roller assembly vertically, with broken end of spring towards the ground. Shake roller assembly up and down above cardboard to pop end cap and spring assembly free from roller tube (Fig. 1). The cardboard is used only to keep spring from striking ground when it shakes loose.
4. Remove spring assembly from roller tube.
5. Cut spring shaft off as shown in Fig.2.  
**Note:** Depending on where the spring shaft has broken, you may need to cut the spring shaft shorter or longer depending on your application.
6. Fit the repair stub over the shaft and weld (Fig. 3).
7. Reassemble the roller assembly.
8. Insert spring shaft through the end plate as shown in Fig. 5.
9. Thread the shaft anchor (part # 501-0816) onto spring shaft (Fig. 5).
10. Line up holes in end plate to the holes in shaft anchor and bolt in place as shown in Fig. 5.

Fig. 1

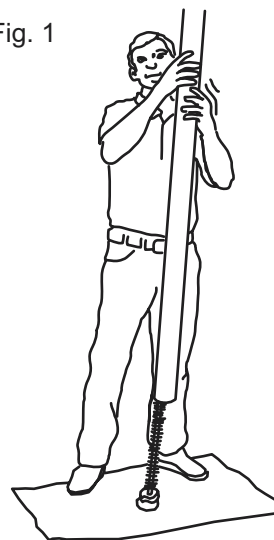

Fig. 2

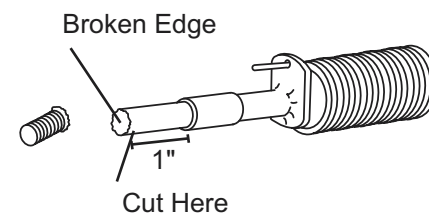
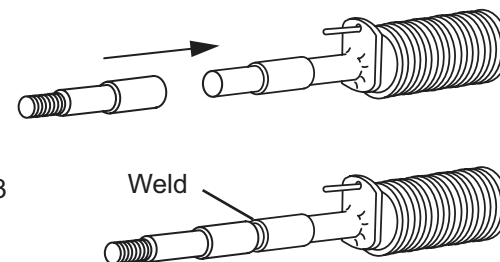

Fig. 3



## \*WARNING\*

A plastic bushing is installed under the spring. To Prevent the plastic from melting while welding the replacement end you must wrap the spring end with a wet rag. Try and direct the heat from your welding away from the spring end.

Fig. 4

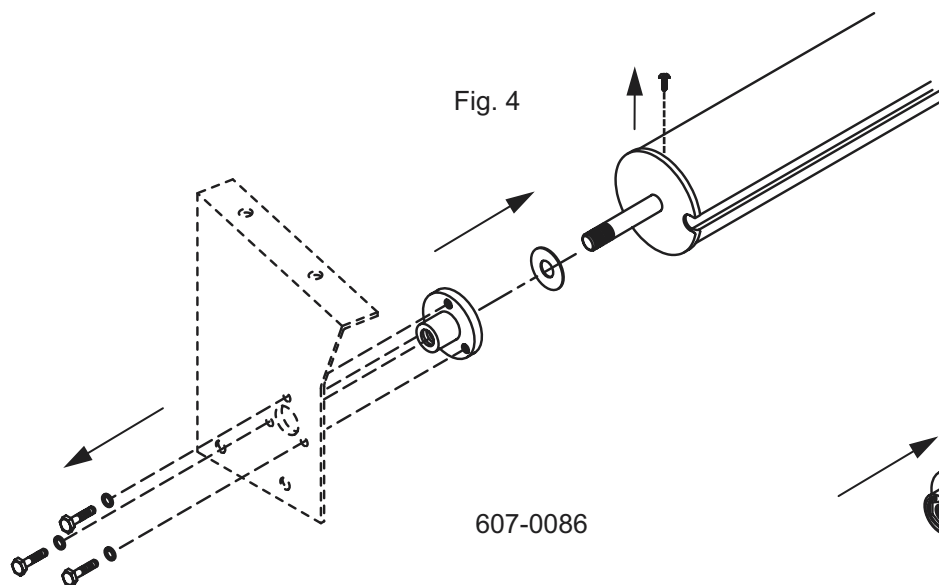

607-0086

Fig. 5

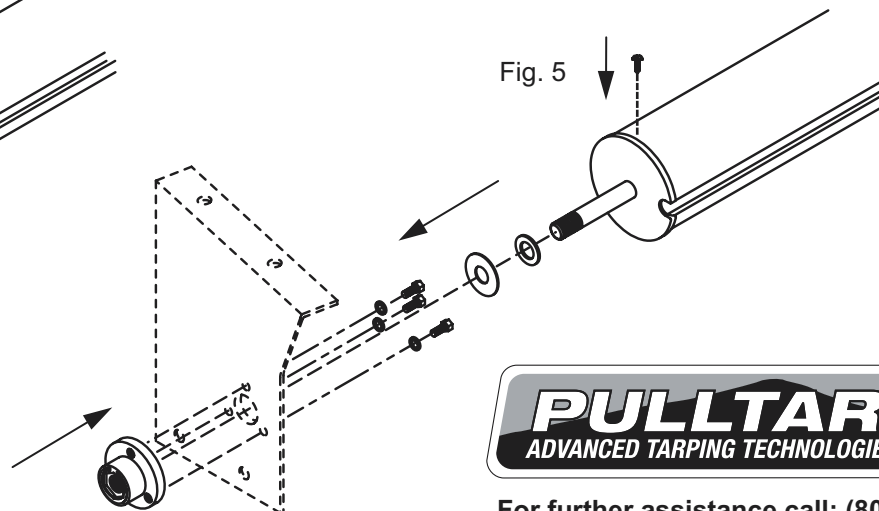

For further assistance call: (800) 368-3075