

Optional Tarp Tamer

Part # 501-0701

Fig. 1

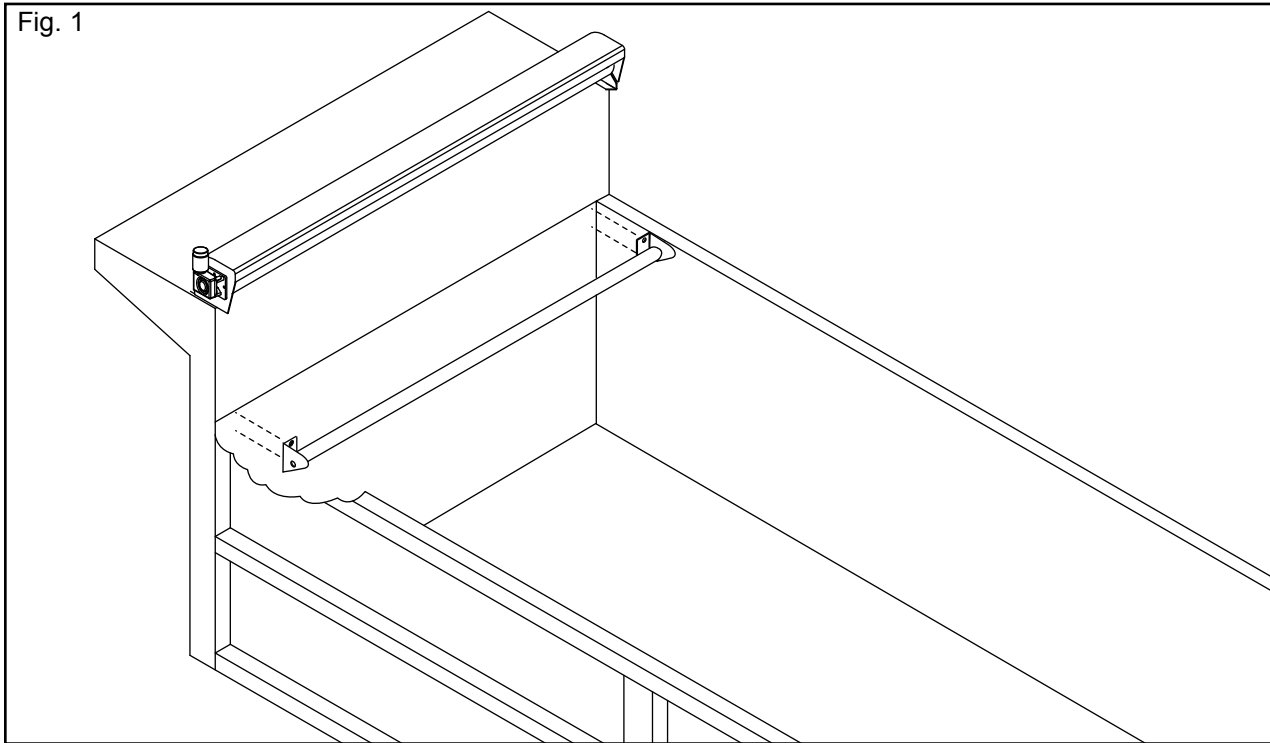

Step 1

Choose mounting location and cut tube to length as needed.

Step 2.

Fasten Tarp Tamer against bulkhead or top rails with 506-3703 self threading screws or weld in place (Fig. 1).

Step 3.

Rout tarp under roller (Fig. 2).

Fig. 2

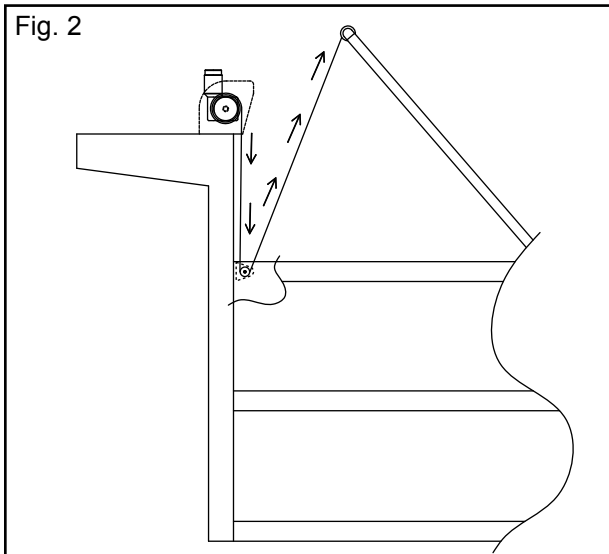

Fig. 3
Tarp In

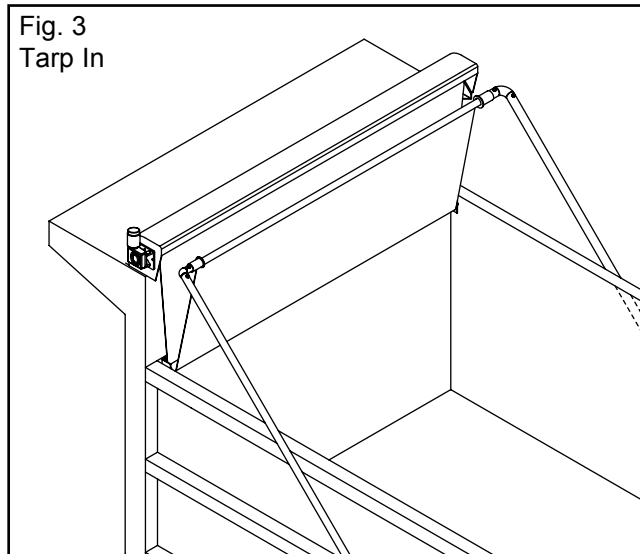
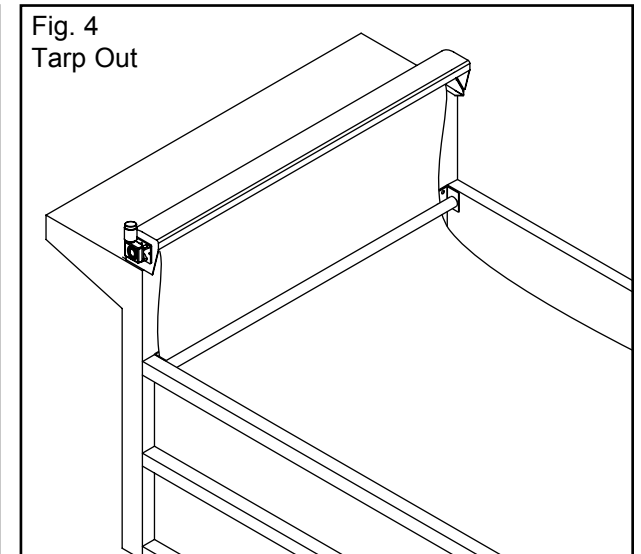
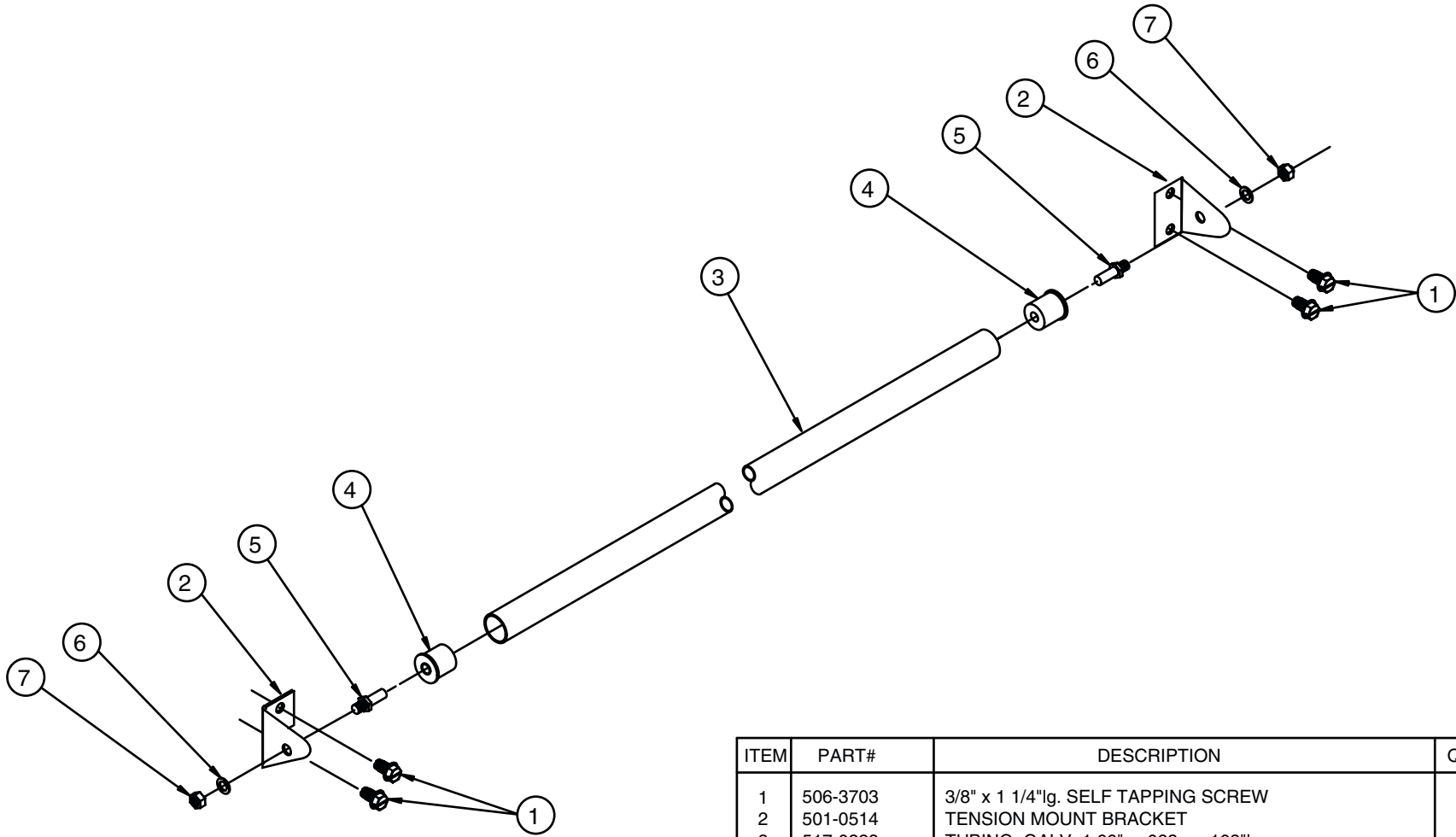

Fig. 4
Tarp Out



TARP TAMER (#501-0701)



ITEM	PART#	DESCRIPTION	QTY
1	506-3703	3/8" x 1 1/4"lg. SELF TAPPING SCREW	4
2	501-0514	TENSION MOUNT BRACKET	2
3	517-0323	TUBING, GALV. 1.66" x .083w x 103"lg.	1
4	501-9939	UHMW BUSHING, TARP TAMER	2
5	501-0801	SYSTEM END PLATE STUD 2.4"	2
6	505-5001	1/2" AN FLAT WASHER	2
7	504-5001	1/2" CRIMP NUT	2

BAB REV: 11/13/07