

Smart Switch Basic Kit - 12 volt (514-0114)

Wiring Instructions

NB 8/12/11

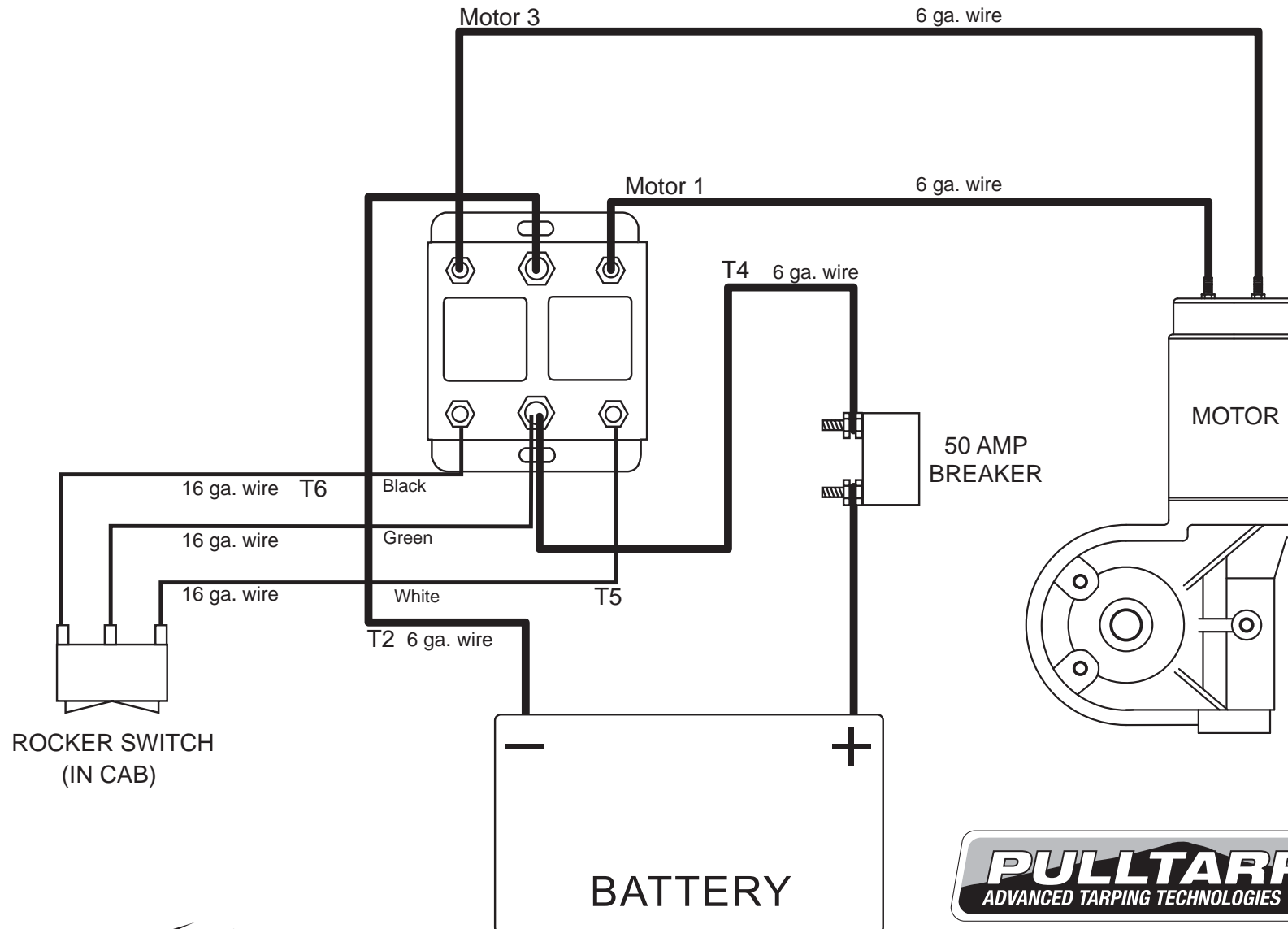

Smart  **Switch**™

607-0089



1404 N. Marshall Ave, El Cajon, CA 92020
For Technical Assistance
Call Toll Free: (800) 368-3075

Step. 1

Run the 6 ga. wire to both locations (motor & battery box) and attach to truck body as shown in Fig. 1.

Note: The wire must go beyond the pivot point.

Caution: Make sure wire does not get pinched at the pivot.

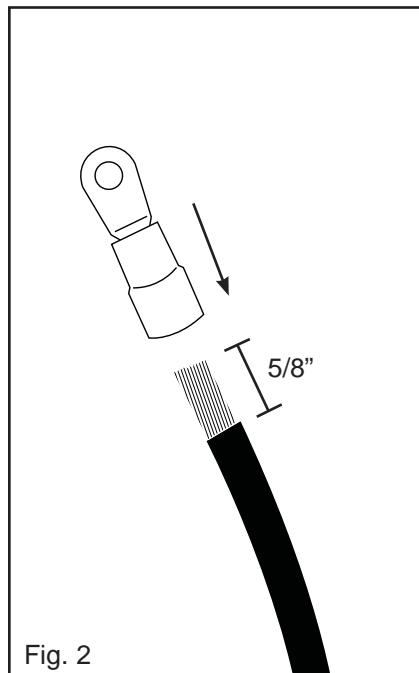
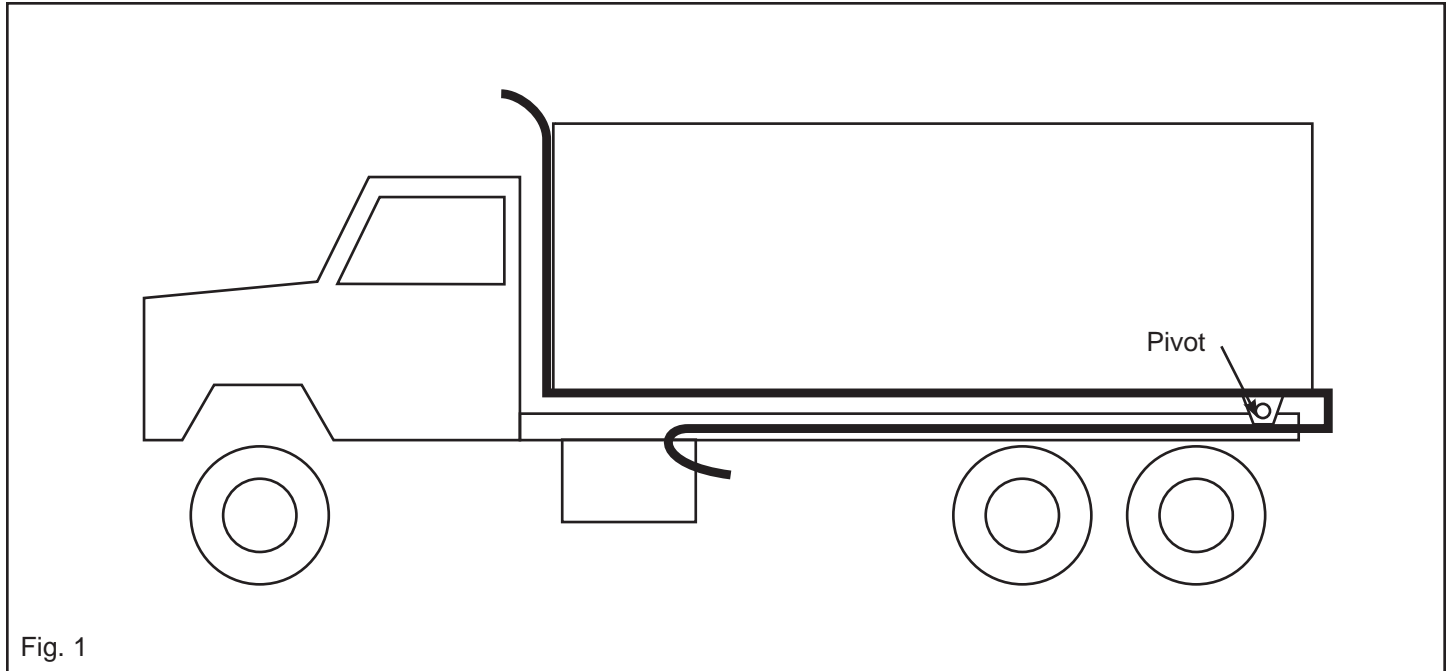

Step 2. Attaching The Connectors (Motor)

- A. Split the molded 6 ga. wire approximately 4" and strip the ends about 5/8" down.
- B. Attach connectors (part # 514-0308) and crimp (Fig. 2).
- C. Attach black wire to Terminal # 1 on motor (Fig. 3).
- D. Attach red striped wire to Terminal # 2 on motor (Fig. 3).

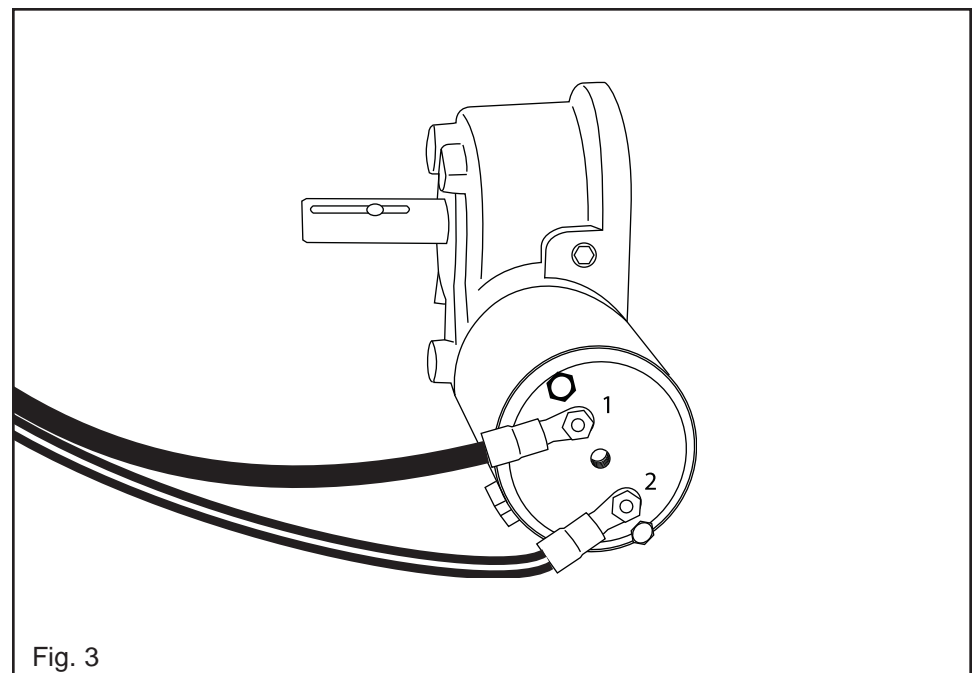

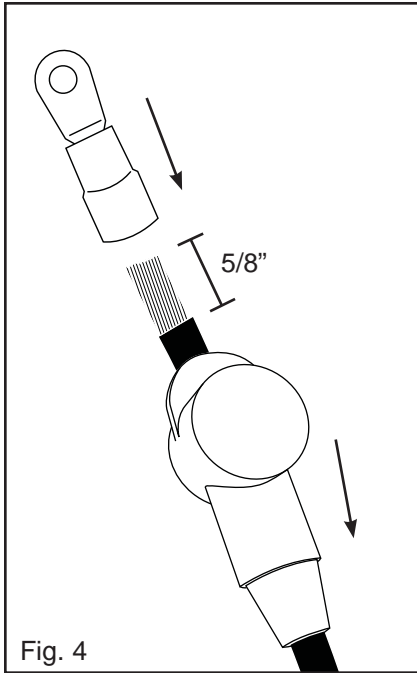

Fig. 4

Step 3.

- A. Locate the Solenoid in a ventilated area near the battery. Mount using the self drilling screws (part # 506-9904).
- B. Split the 6 ga. wire at the solenoid about 4" back and slip on rubber boots - Red Boot (part # 514-0336) on red striped wire and Black Boot (part # 514-0337) on black wire (Fig. 4 & 5).
- C. Strip wire about 5/8" and attach connectors (part # 514-0328) (Fig. 4). Crimp Connectors.
- D. Attach Red to IN and Black to OUT on Solenoid (Fig. 5).

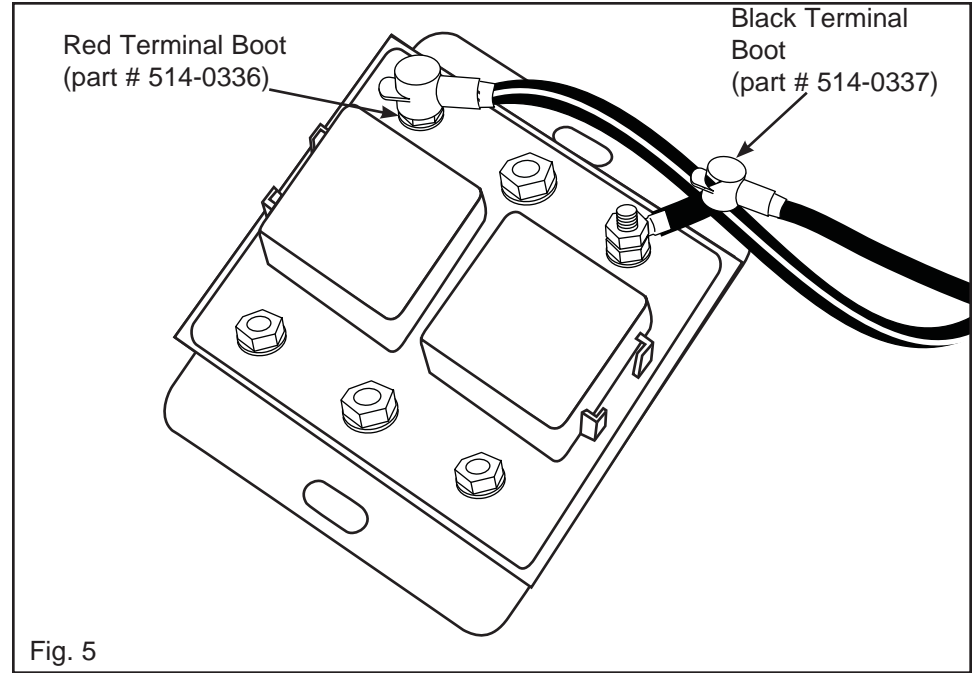

Fig. 5

Do not over tighten nuts on Solenoid!

Step 4. Run 16 ga. Wire to Cab from solenoid

- A. Mount Switch Bracket (part # 514-9954) in a convenient place in cab using the two self drilling screws (part # 506-9904).
- B. Strip wire in cab about 1/4" and attach push on connectors (part # 514-0321) and crimp (Fig. 6).
- C. Pull wire through Switch Bracket (part # 514-9954) (Fig. 6).
- D. Attach wire to Rocker Switch (part # 514-0117) (Fig. 6).
Green to Center
Black to Top
White to Bottom
- E. Snap Rocker Switch firmly in Switch Bracket.

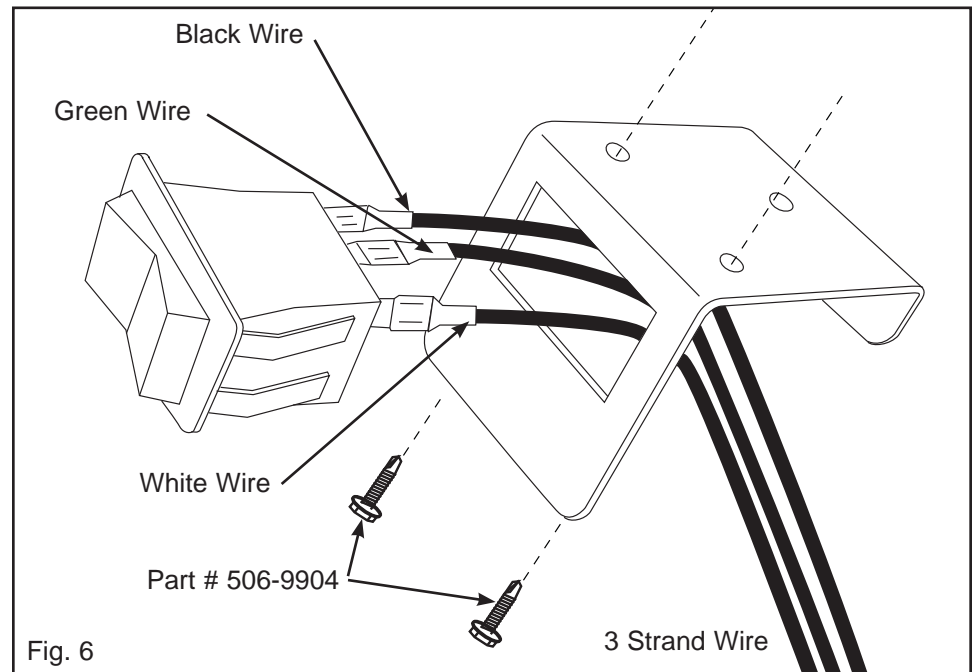
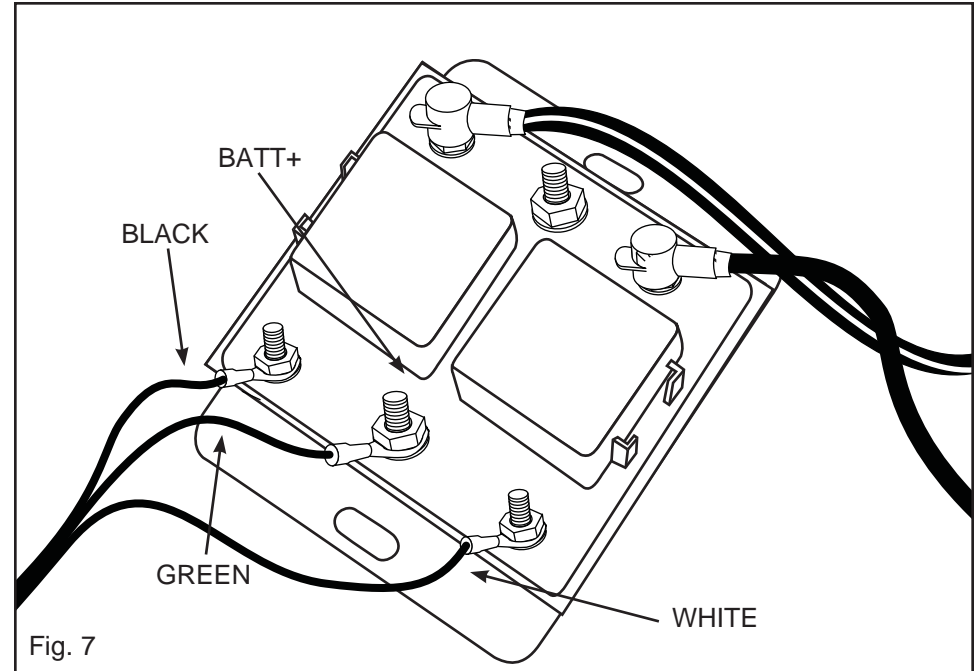

Fig. 6

Step 5. Attaching Switch Wires to Solenoid

- A. On the black and white wires only, strip ends about 1/4" and attach #10 loop connectors (part # 514-0303).
- B. On the green wire, strip end about 1/4" and attach connector with 1/4" eyelet (part # 514-0304).
- C. Attach Black to LEFT Terminal on Solenoid (Fig. 7).
Attach White to RIGHT Terminal on Solenoid (Fig. 7).
Attach Green to BATT+ on Solenoid (Fig. 7).



Step 6. Connecting the Solenoid to the Battery

- A. Cut a length of wire to run between the battery and the solenoid.
- B. Split wire about 4" down and strip ends about 5/8". Slip on Red Boot (part # 514-0336) on Red Striped Wire and Black Boot (part # 514-0337) on Black Wire as done in Step 3.
- C. Attach Connectors (part # 514-0328) and crimp to wires.
- D. Attach Red Striped wire to BATT+ on Solenoid, and tighten nut (Fig. 8).
- E. DO NOT attach Black wire to BATT- on Solenoid at this time.

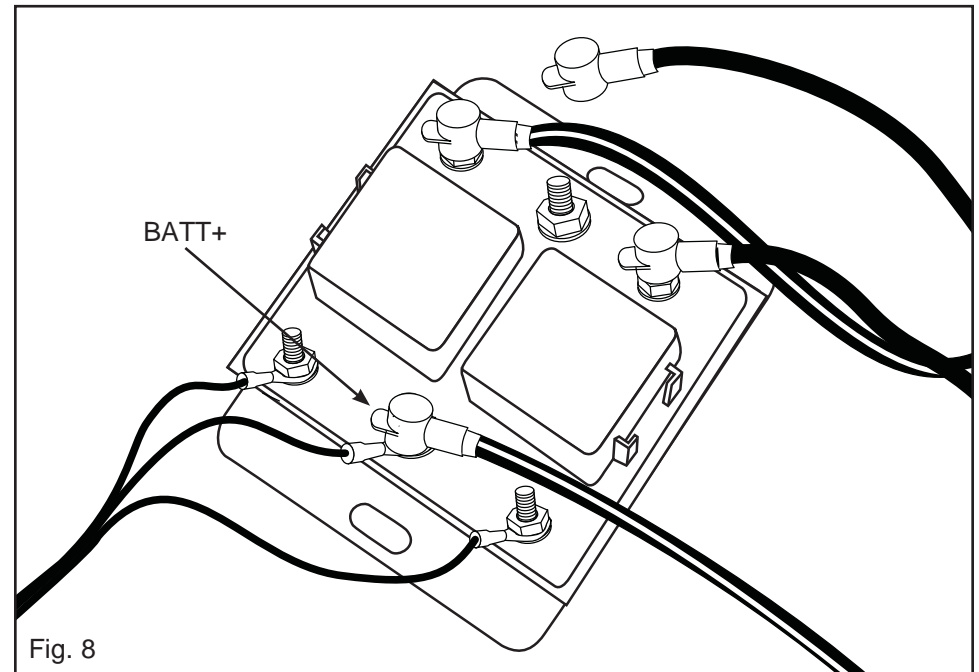

Step 7. Hooking up the Breaker

- A. Mount the Breaker in the Battery Box away from moisture and so that it won't short out on the battery lid or terminals.
- B. Split a section of the 6 ga. wire that runs from BATT+ on the Solenoid to the Breaker as needed.
- C. Cut and then strip ends of the Red Striped Wire about 5/8" and attach the #10 terminal ends (Part # 514-0307) only to the Red Striped Wire.
- D. Attach to Breaker. The breaker is marked "Load" at the Solenoid end and "Line" at the Battery end.

Warning: Failure to install properly will void warranty on motor and other parts.

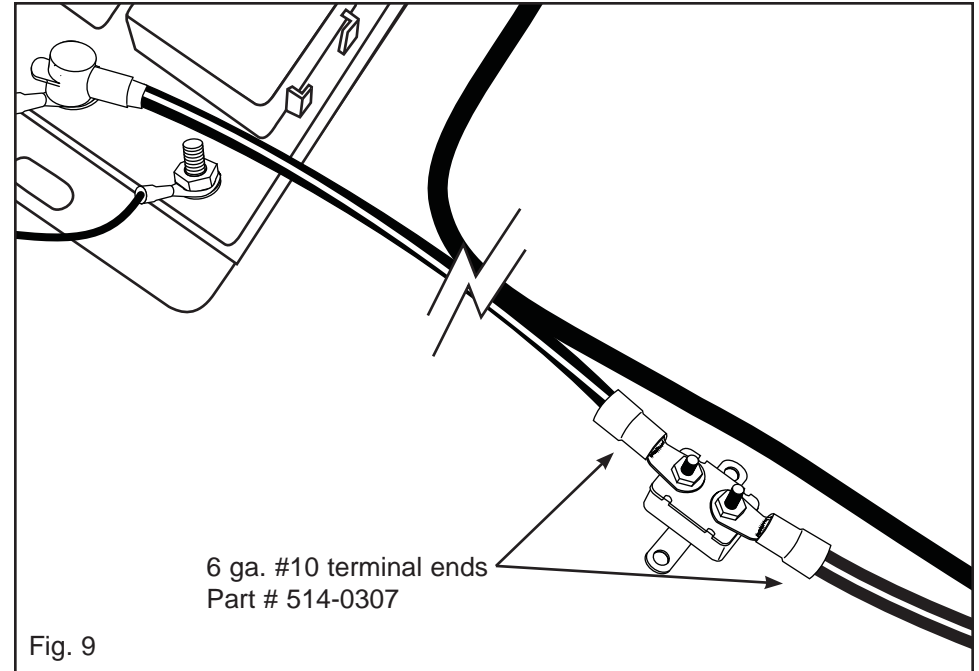

Step 9. Hooking up the Battery

- A. Split the 6 ga. wire that runs from BATT+ and BATT- on the Solenoid about 4".
- B. Strip the ends about 5/8" and attach the 3/8" connectors (part # 514-0309), crimp to wires.
- C. Attach Red Striped wire to Positive Terminal on Battery (Fig. 11). Attach Black wire to Negative Terminal on Battery (Fig. 11).

Note: If the system operates backwards, reverse the connections on the motor.

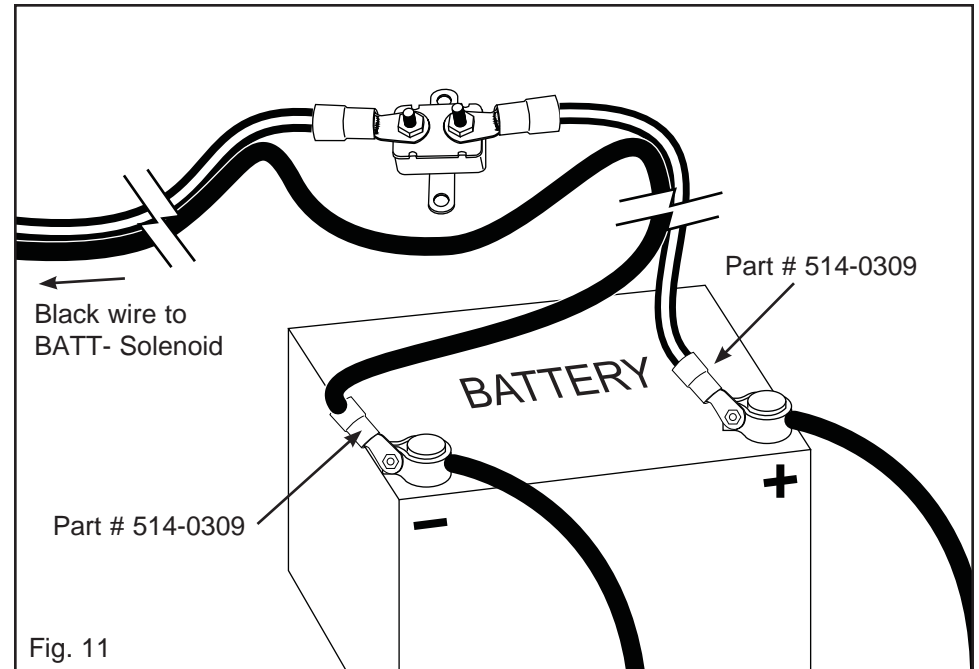

Smart Switch Basic Kit (Part # 514-0114)

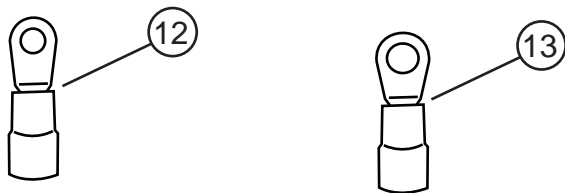
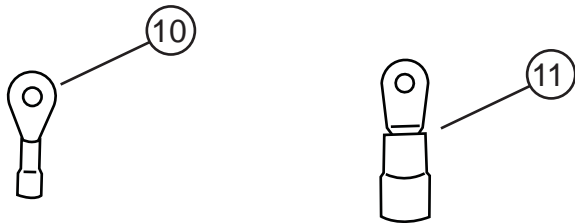
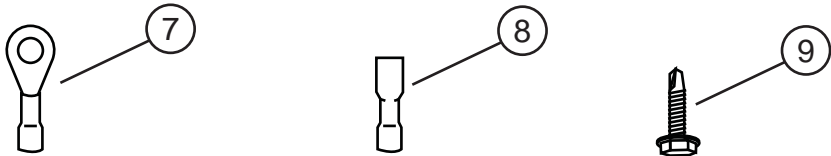
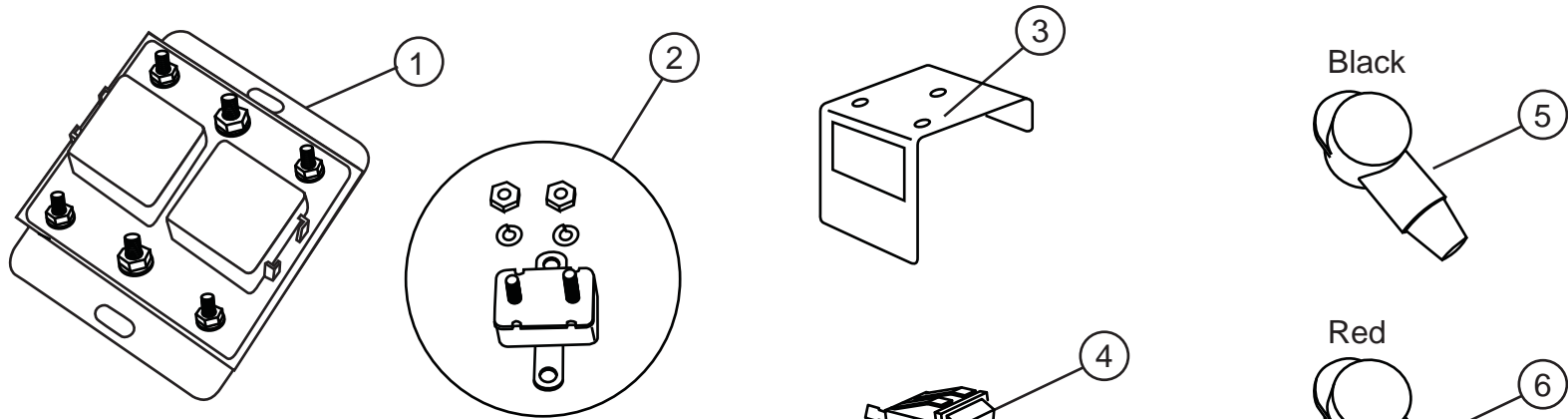

Item #	Part #	Description:	QTY:
1	514-9967	Reversing Polarity 12v Solenoid	1
2	514-0408	50 Amp Type II Breaker	1
3	514-9954	Rocker Switch Bracket	1
4	514-0117	Rocker Switch 3 Position Momentary	1
5	514-0337	Black Terminal Boot	2
6	514-0336	Red Terminal Boot	2
7	514-0304	Connector 14 ga. Lug with 1/4" Eyelet	1
8	514-0321	Push On Female Terminal 16 ga.	3
9	506-9904	#10 x 3/4" Self Drilling Screw	6
10	514-0303	Connector 14 ga. #10 Stud Eyelet	2
11	514-0307	Connector 6 ga. #10 Stud	2
12	514-0308	Connector 6 ga. Lug with 1/4" Eyelet	6
13	514-0309	Connector 6 ga. Lug with 3/8" Eyelet	2
	514-0211	#16-3 Wire PVC 27# Copper	25 Ft.

BAB REV. 1/23/09

Motor check out procedure:

1. Remove leads from motor & attach volt meter to the leads.
2. With the switch in to on position, the volt meter should read 12 volts minimum. If voltage is low recheck with engine running. Recheck wiring and connections (minimum 6 gauge wire must be used.)
3. Return switch to the neutral position & reattach leads to motor.
4. Attach volt meter to leads at the motor.
5. With the switch in the on position and the leads attached, the volt meter should read 8.5 volts minimum. If voltage is low recheck with engine running. Recheck wiring and connections (minimum 6 gauge wire must be used).
6. Return switch to the neutral position and attach amp meter to leads at the motor.
7. With the switch in the on position, amp meter should read approximately 30 amps. Constant amperage reading of over 50 amps indicated binding in the system and/or low voltage.
8. Disconnect 6 ga #10 terminal end from the solenoid side of the breaker.
9. Connect the 6 ga #10 terminal end to the battery side of the breaker. This will bypass the breaker.
10. Test the tarp system. If the motor operates properly then replace the breaker.

