

# Smart Switch with Cab / External Switch - 12 volt (501-9952)

Wiring Instructions

NB 02/09/10

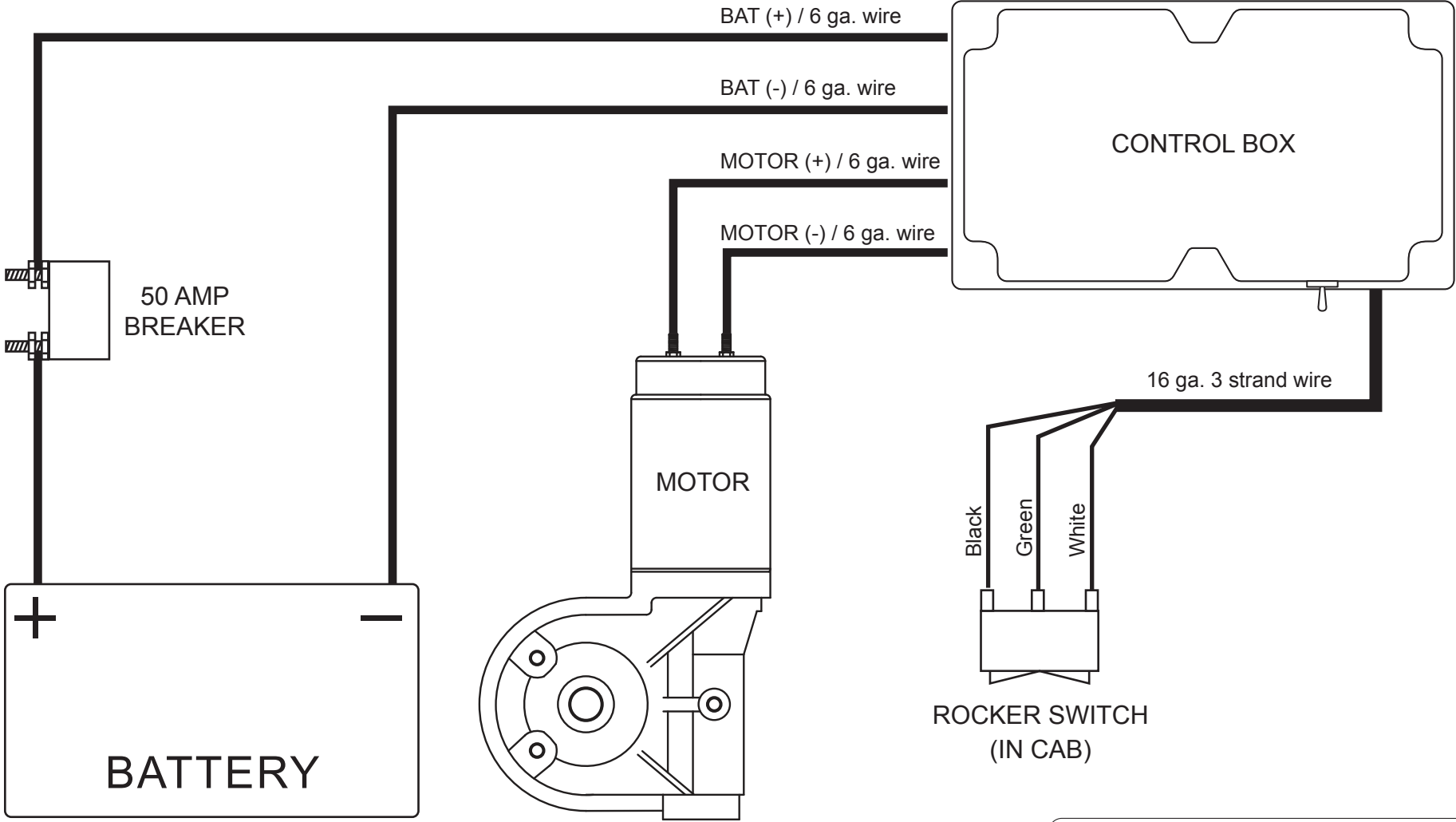

**Smart**  **Switch**™

607-0093



1404 N. Marshall Ave, El Cajon, CA 92020  
For Technical Assistance  
Call Toll Free: (800) 368-3075

**Step. 1**

Run the 6 ga. wire to both locations (motor & battery box) and attach to truck body as shown in Fig. 1.

**Note:** The wire must go beyond the pivot point.

**Caution:** Make sure wire does not get pinched at the pivot.

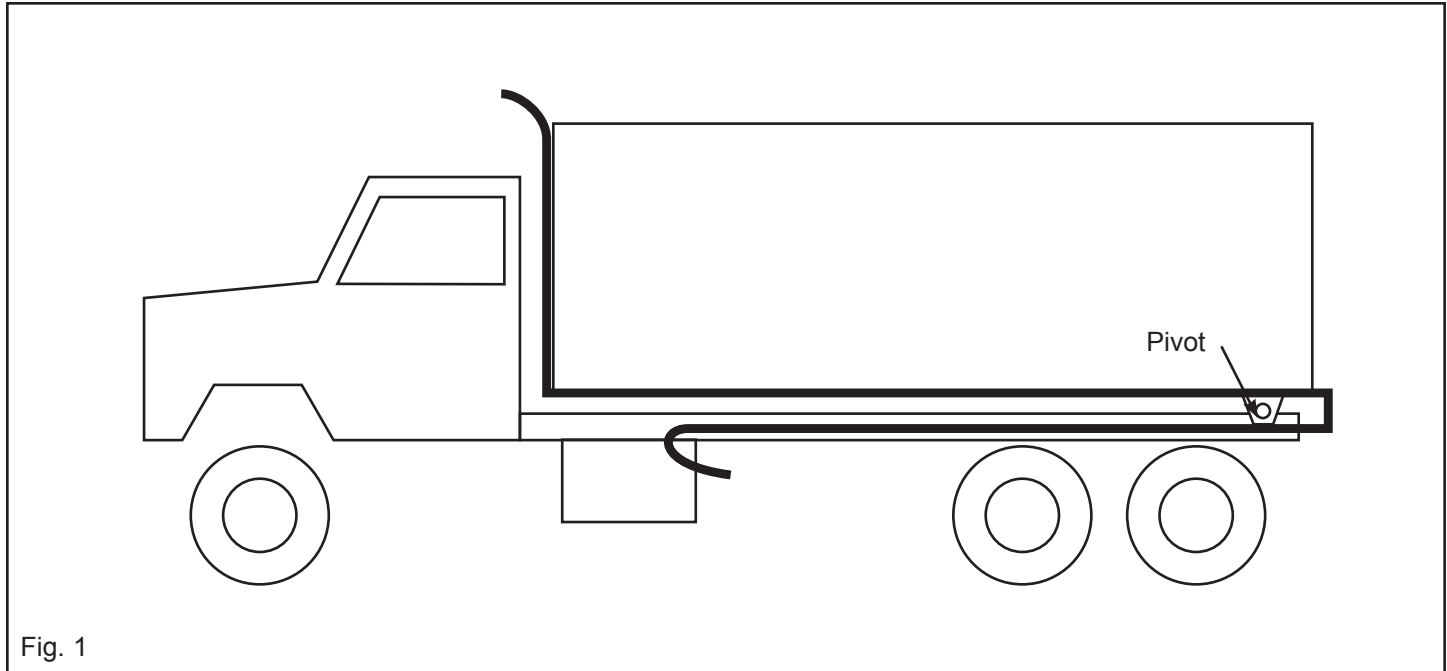

Fig. 1

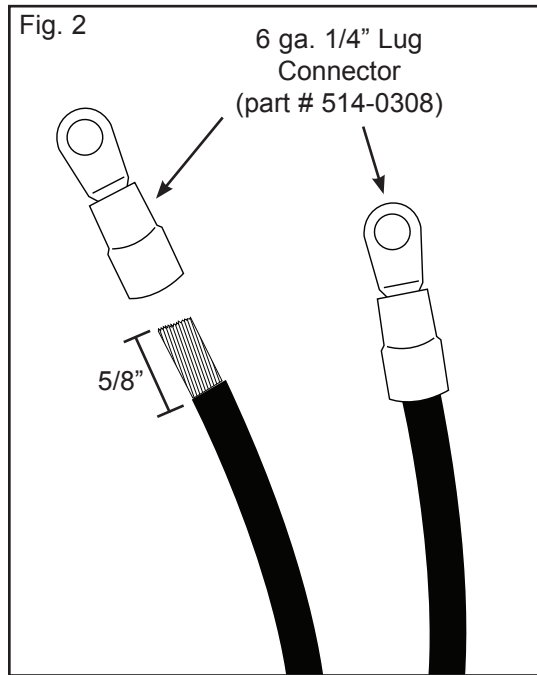

Fig. 2

**Step 2. Attaching The Connectors (Motor)**

- A. Split the molded 6 ga. wire approximately 4" and strip the ends about 5/8" down.
- B. Attach connectors (part # 514-0308) and crimp (Fig. 2).
- C. Attach black wire to Terminal # 1 on motor (Fig. 3).
- D. Attach red striped wire to Terminal # 2 on motor (Fig. 3).

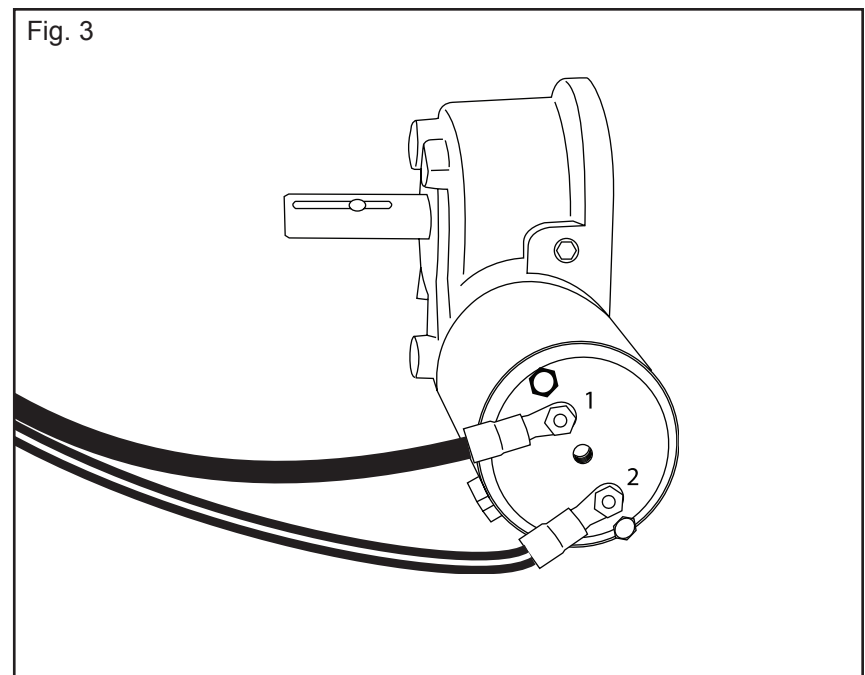
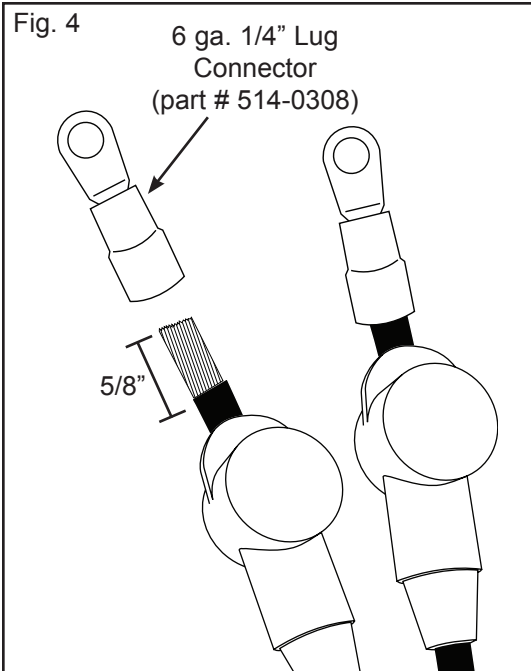

Fig. 3



### Step 3.

- A. Mount the Control Box near the battery.
- B. Split the 6 ga. wire at the Control Box about 4" back and slip on rubber boots - Red Boot (part # 514-0319) on red striped wire and Black Boot (part # 514-0317) on black wire (Fig. 4 & 5).
- C. Strip wire about 5/8" and attach connectors (part # 514-0308) (Fig. 4). Crimp Connectors.
- D. Attach Red Striped wire to Motor (+) and Black wire to Motor (-) on Control Box (Fig. 5).

Do not over tighten nuts on connections!

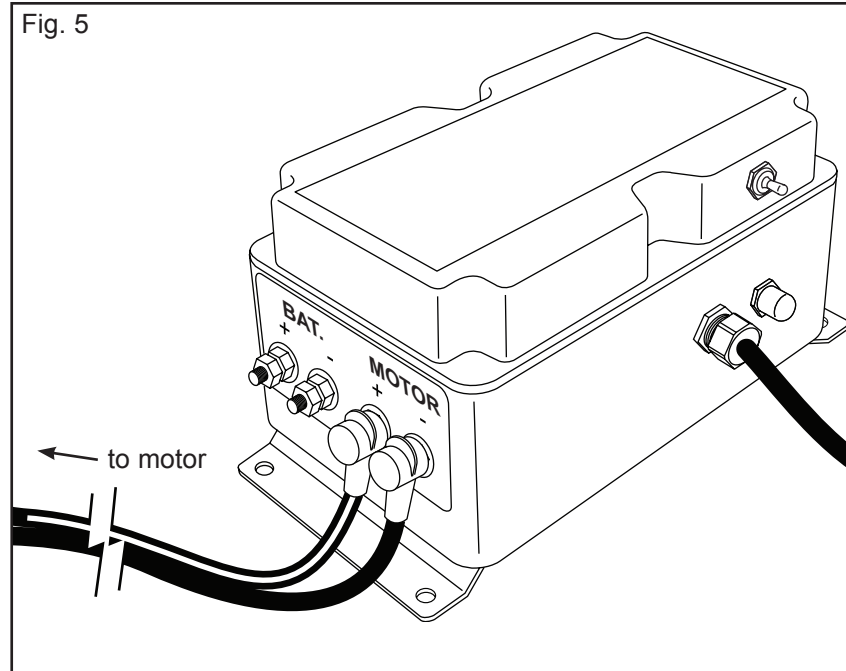

### Step 4. Run 16 ga. Wire to Cab from solenoid

- A. Mount Switch Bracket (part # 514-9954) in a convenient place in cab using the two self drilling screws (part # 506-9904).
- B. Run the 3 Strand wire to the cab switch location.
- C. Strip wire in cab about 1/4" and attach push on connectors (part # 514-0321) and crimp (Fig. 6).
- D. Pull wire through Switch Bracket (part # 514-9954) (Fig. 6).
- E. Attach wire to Rocker Switch (part # 514-0117) (Fig. 6).  
**Green to Center**  
**Black to Top**  
**White to Bottom**
- F. Snap Rocker Switch firmly in Switch Bracket.

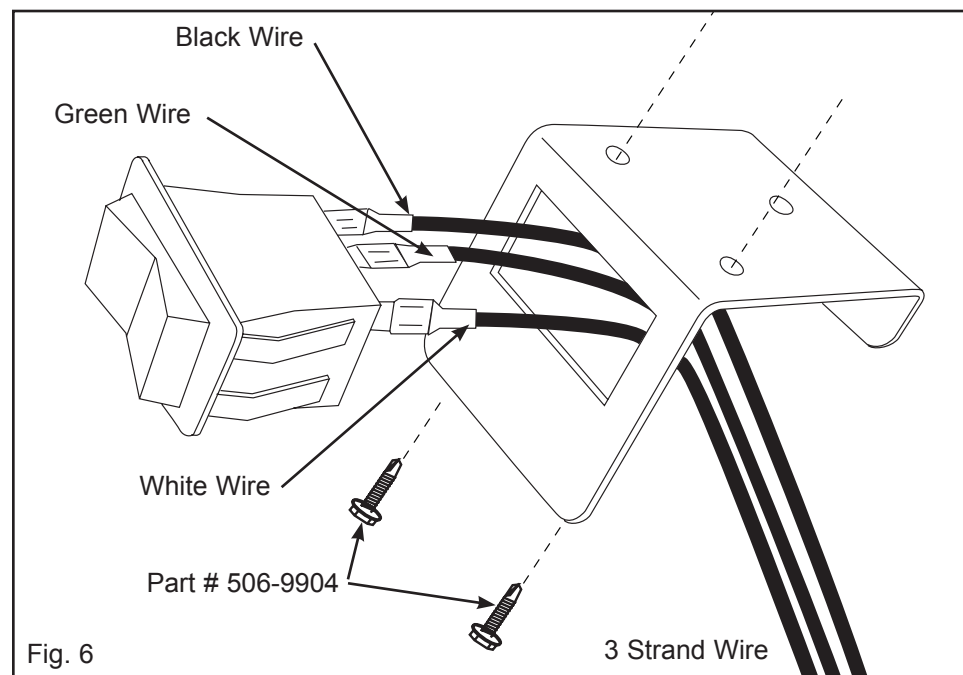
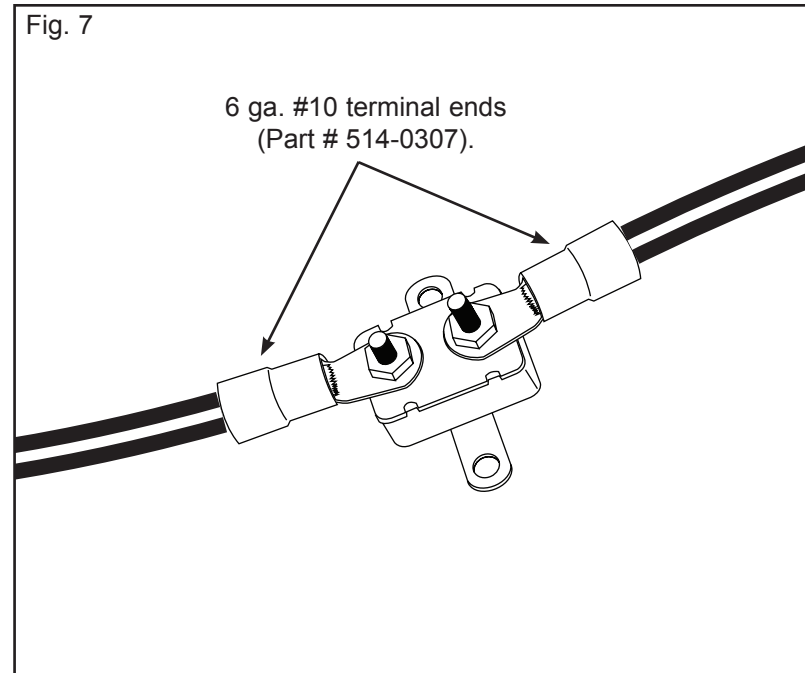

Fig. 6

### Step 5. Wiring the Breaker

- A. Mount breaker in the battery box away from moisture.
- B. Cut a section in the red 6 ga. wire that will run to the positive terminal on the battery.
- C. Strip the ends about 5/8" and attach the 6 ga. #10 terminal ends (Part # 514-0307).
- D. Attach to breaker.



### Step 6. Wiring the Battery

- A. Attach the red striped 6 ga. wire to BAT (+) at the control box. Slide Red Terminal Boot over the end and connect using the Lug Connector (part # 514-0308) as done in step 3.
- B. Attach the other end of the red striped 6 ga. wire to the positive terminal on the battery using a 6 ga. 3/8" terminal end part # 514-0309 or 1/4" terminal end (part # 514-0309), depending on the size of the terminal at the battery. (Fig. 8).

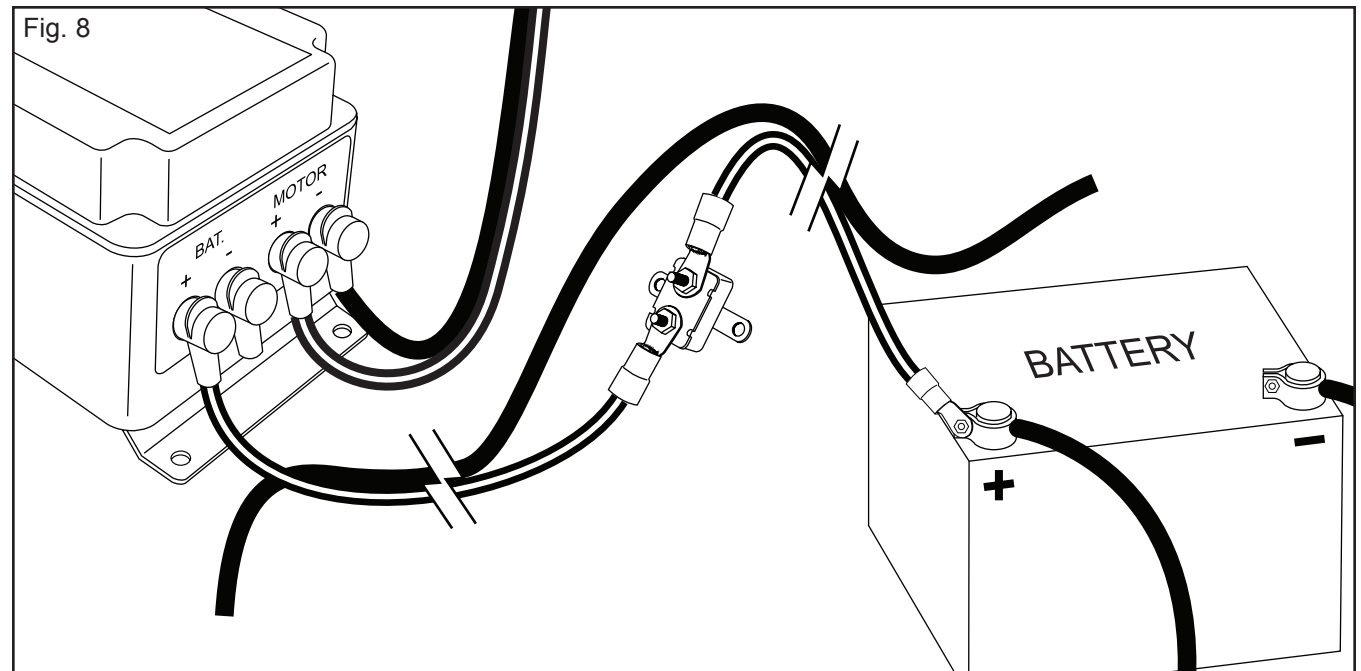

### Step 7. Wiring the Battery

- A. Connect the black 6 ga. wire to the negative terminal on the battery using a 6 ga. 3/8" terminal end (part # 514-0309) or 1/4" terminal end (part # 514-0309), depending on the size of the terminal at the battery. (Fig. 9).
- B. Attach the other end of the black 6 ga. wire to BAT (-) at the control box as done in step 3. Slide Black Terminal Boot over the end and connect using the Lug Connector (part # 514-0308) as shown in Fig. 9.

**Warning:** You must attach the black 6 ga. wire to the battery first, before attaching it to the box.

**Note:** If the system operates backwards then reverse the 6 ga. wires on the motor.

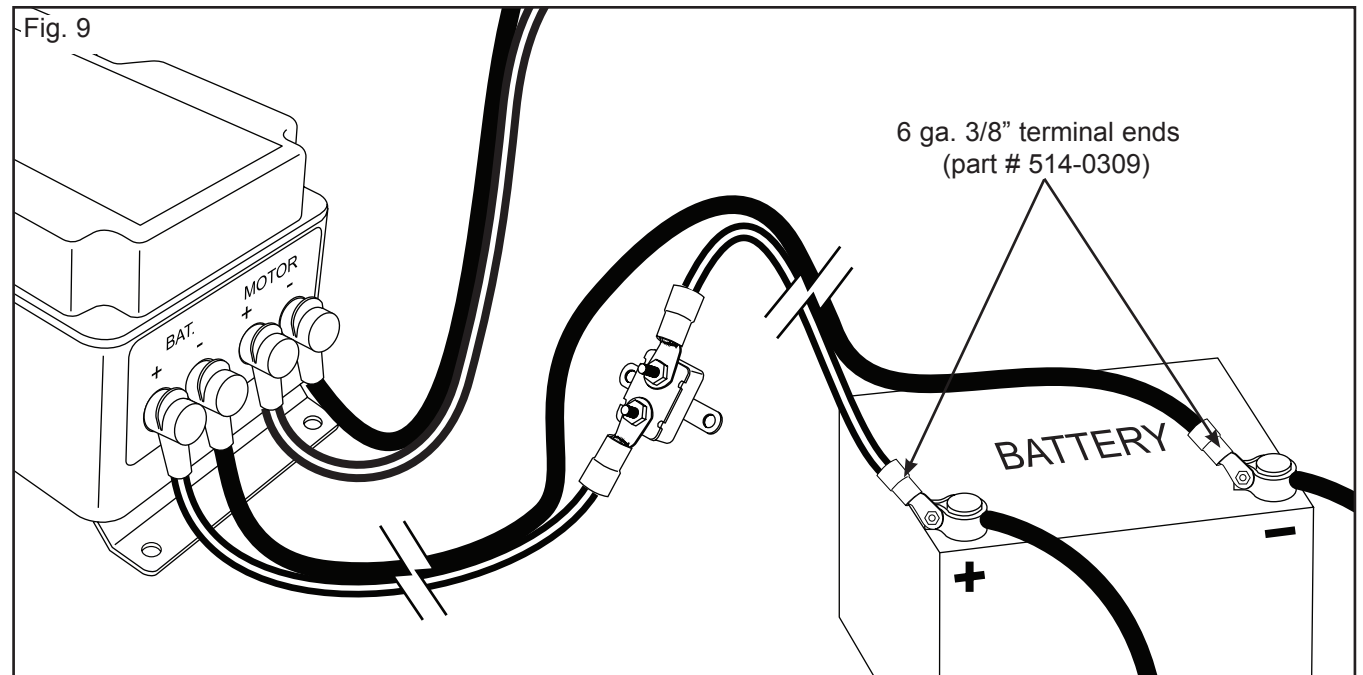

# Smart Switch with Cab / External Switch - 12 volt (501-9952)

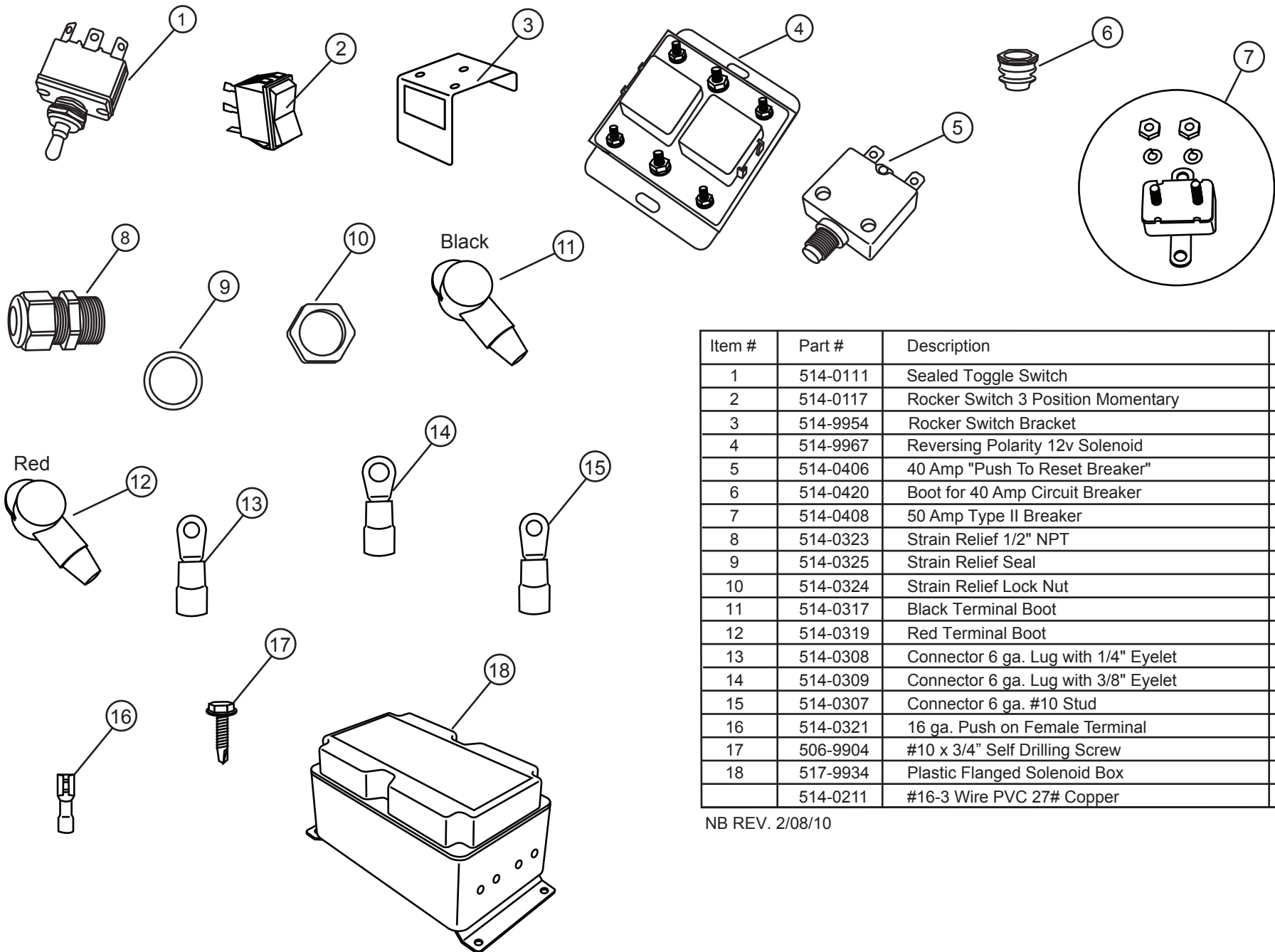

Item #	Part #	Description	QTY:
1	514-0111	Sealed Toggle Switch	1
2	514-0117	Rocker Switch 3 Position Momentary	1
3	514-9954	Rocker Switch Bracket	1
4	514-9967	Reversing Polarity 12v Solenoid	1
5	514-0406	40 Amp "Push To Reset Breaker"	1
6	514-0420	Boot for 40 Amp Circuit Breaker	1
7	514-0408	50 Amp Type II Breaker	1
8	514-0323	Strain Relief 1/2" NPT	1
9	514-0325	Strain Relief Seal	1
10	514-0324	Strain Relief Lock Nut	1
11	514-0317	Black Terminal Boot	2
12	514-0319	Red Terminal Boot	2
13	514-0308	Connector 6 ga. Lug with 1/4" Eyelet	6
14	514-0309	Connector 6 ga. Lug with 3/8" Eyelet	2
15	514-0307	Connector 6 ga. #10 Stud	2
16	514-0321	16 ga. Push on Female Terminal	3
17	506-9904	#10 x 3/4" Self Drilling Screw	2
18	517-9934	Plastic Flanged Solenoid Box	1
	514-0211	#16-3 Wire PVC 27# Copper	25 Ft.

NB REV. 2/08/10

## Motor check out procedure:

1. Remove leads from motor & attach volt meter to the leads.
2. With the switch in to on position, the volt meter should read 12 volts minimum. If voltage is low recheck with engine running. Recheck wiring and connections (minimum 6 gauge wire must be used.)
3. Return switch to the neutral position & reattach leads to motor.
4. Attach volt meter to leads at the motor.
5. With the switch in the on position and the leads attached, the volt meter should read 8.5 volts minimum. If voltage is low recheck with engine running. Recheck wiring and connections (minimum 6 gauge wire must be used).
6. Return switch to the neutral position and attach amp meter to leads at the motor.
7. With the switch in the on position, amp meter should read approximately 30 amps. Constant amperage reading of over 50 amps indicated binding in the system and/or low voltage.
8. Disconnect 6 ga #10 terminal end from the solenoid side of the breaker.
9. Connect the 6 ga #10 terminal end to the battery side of the breaker. This will bypass the breaker.
10. Test the tarp system. If the motor operates properly then replace the breaker.

