

Smart Switch with External Switch - 12 volt - (501-9953)

Wiring Instructions

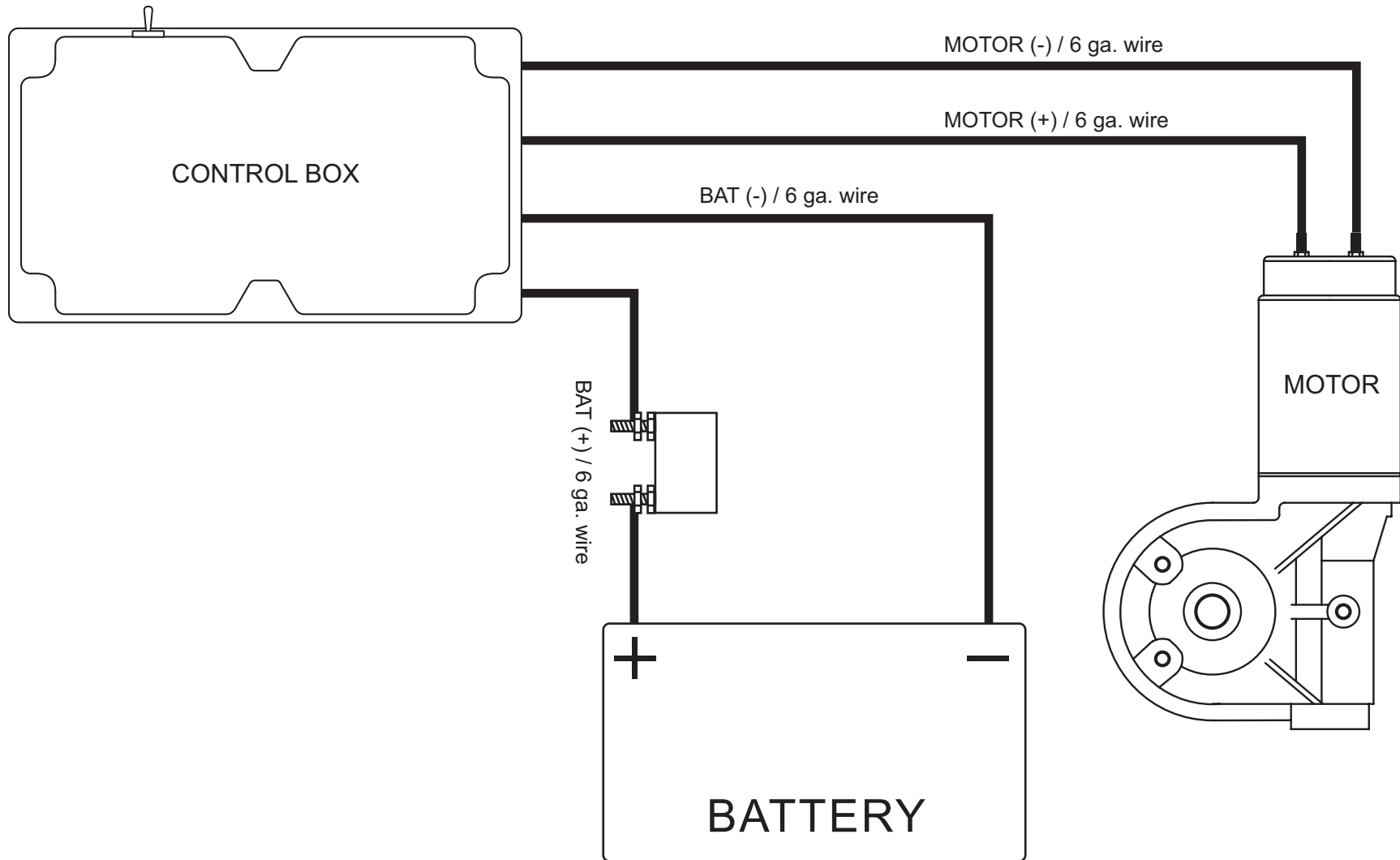

1404 N. Marshall Ave, El Cajon, CA 92020
For Technical Assistance
Call Toll Free: (800) 368-3075

Step. 1

Run the 6 ga. wire to both locations (motor & battery box) and attach to truck body as shown in Fig. 1.

Note: The wire must go beyond the pivot point.

Caution: Make sure wire does not get pinched at the pivot.

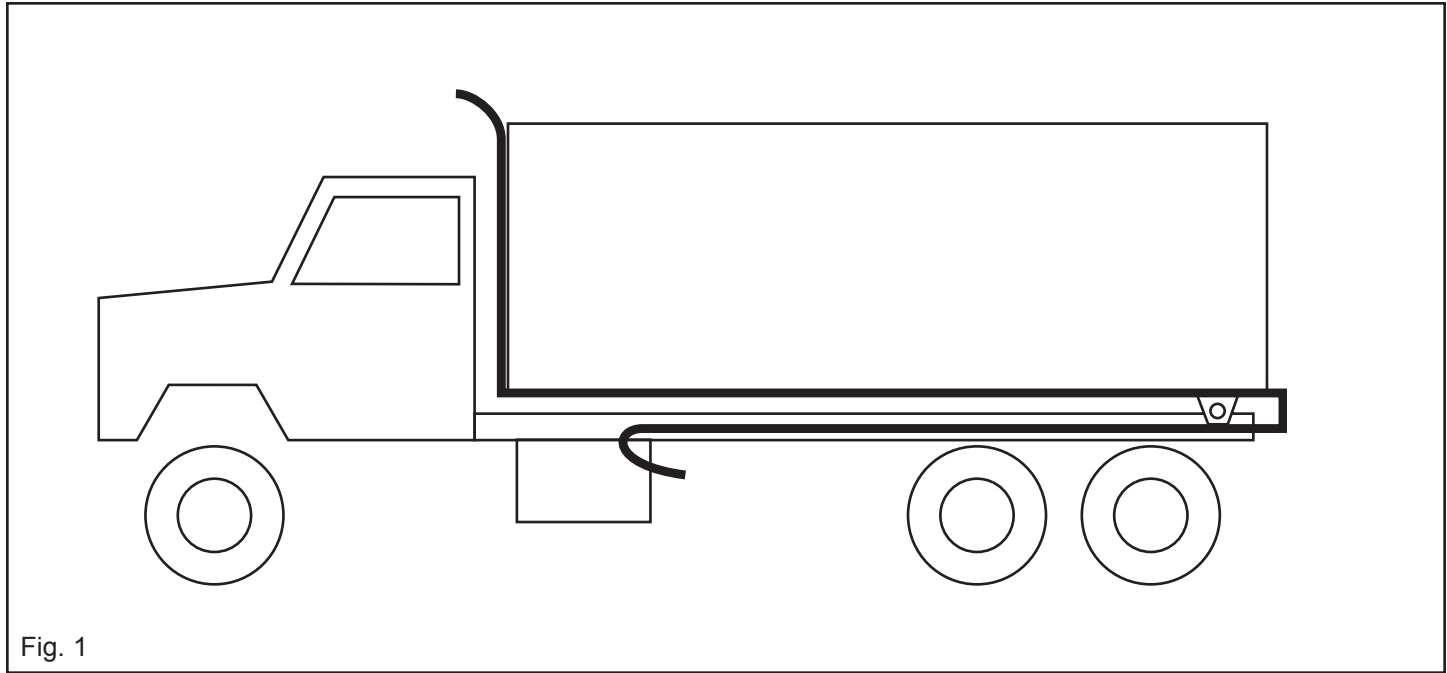
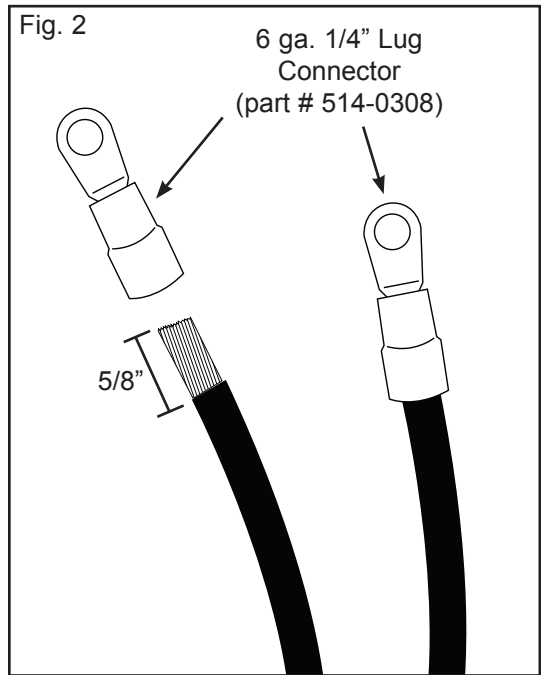

Fig. 1



Step 2. Attaching The Connectors (Motor)

- A. Split the molded 6 ga. wire approximately 4" and strip the ends about 5/8" down.
- B. Attach connectors (part # 514-0308) and crimp (Fig. 2).
- C. Attach black wire to Terminal # 1 on motor (Fig. 3).
- D. Attach red striped wire to Terminal # 2 on motor (Fig. 3).

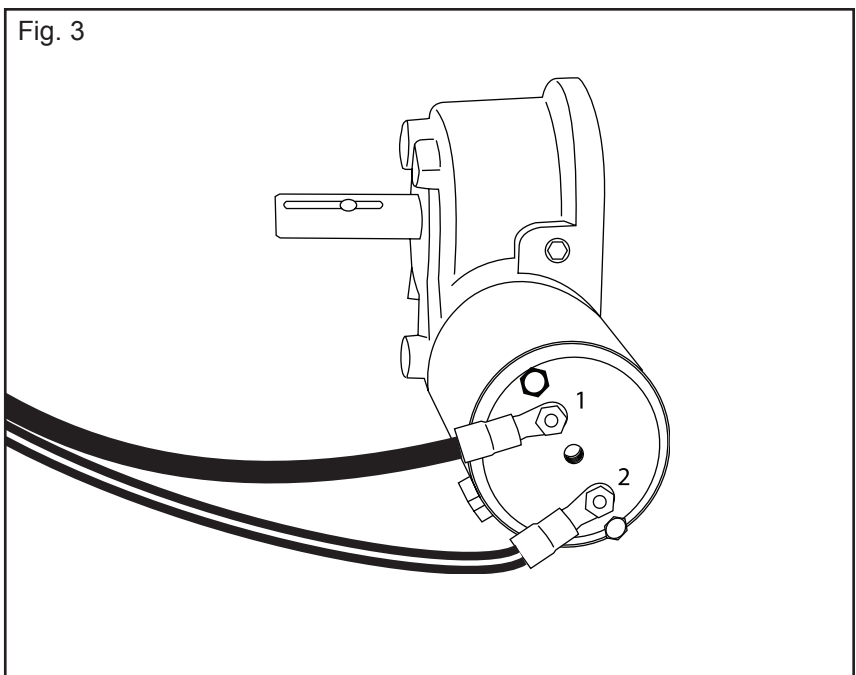
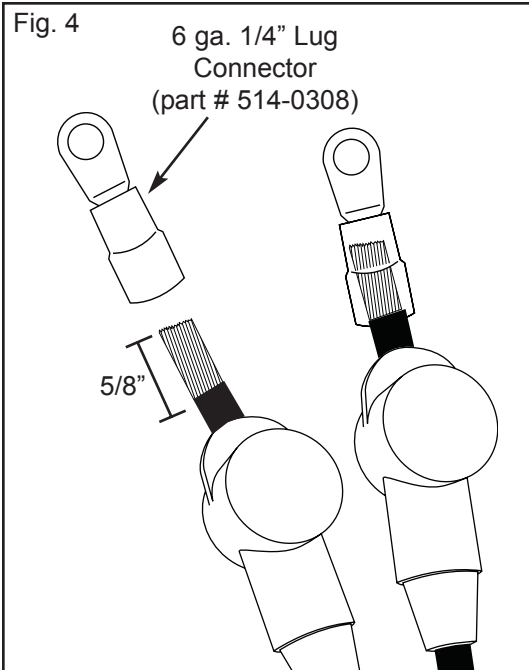

Fig. 3



Step 3.

- A. Mount the control box at tailgate.
- B. Split the 6 ga. wire at the control box about 4" back and slip on rubber boots - Red Boot (part # 514-0319) on red striped wire and Black Boot (part # 514-0317) on black wire (Fig. 4 & 5).
- C. Strip wire about 5/8" and attach connectors (part # 514-0308) (Fig. 4). Crimp Connectors.
- D. Attach red striped wire to motor (+) and black wire to motor (-) on control box (Fig. 5).

Do not over tighten nuts on connections!

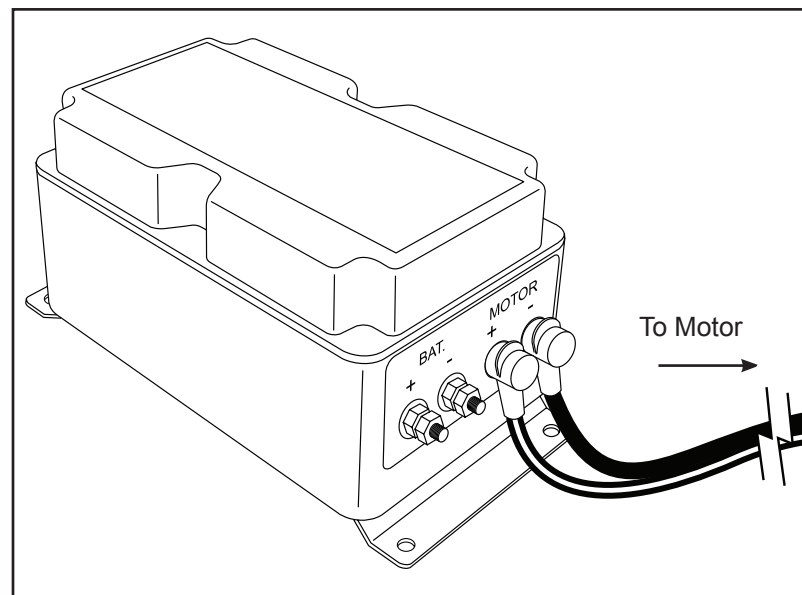

Step 4. Wiring the Breaker

- A. Mount breaker in the battery box away from moisture.
- B. Cut a section in the red 6 ga. wire that will run to the positive terminal on the battery.
- C. Strip the ends about 5/8" and attach the 6 ga. #10 terminal ends (Part # 514-0307).
- D. Attach to breaker.
- E. Wrap entire breaker with black electrical tape to seal out moisture.

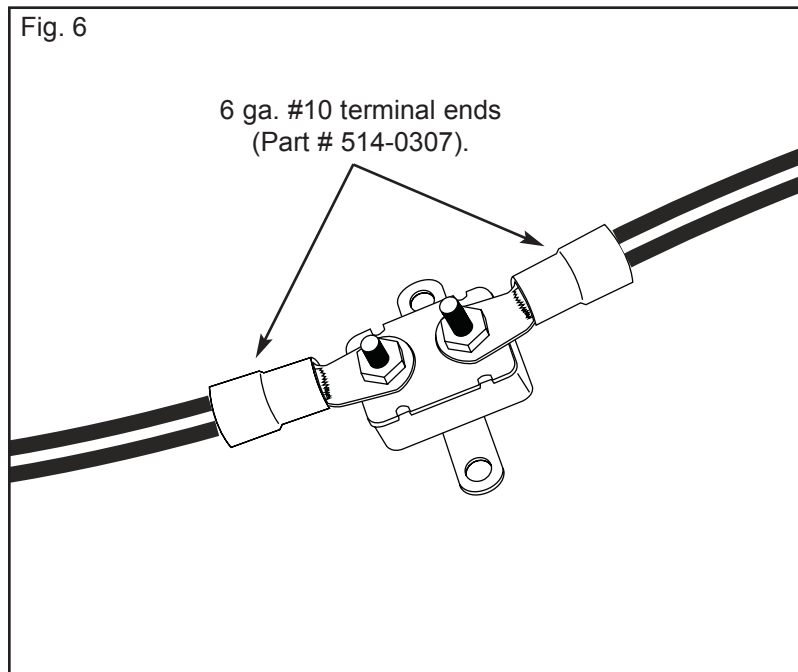

Step 5. Wiring the Battery

- A. Attach the red striped 6 ga. wire to BAT (+) at the control box. Slide Red Terminal Boot over the end and connect using the Lug Connector (part # 514-0308) as done in step 3.
- B. Attach the other end of the red striped 6 ga. wire to the positive terminal on the battery using a 6 ga. 3/8" terminal end (part # 514-0309) or 1/4" terminal end (part # 514-0308) depending on the size of the terminal at the battery. (Fig. 7).

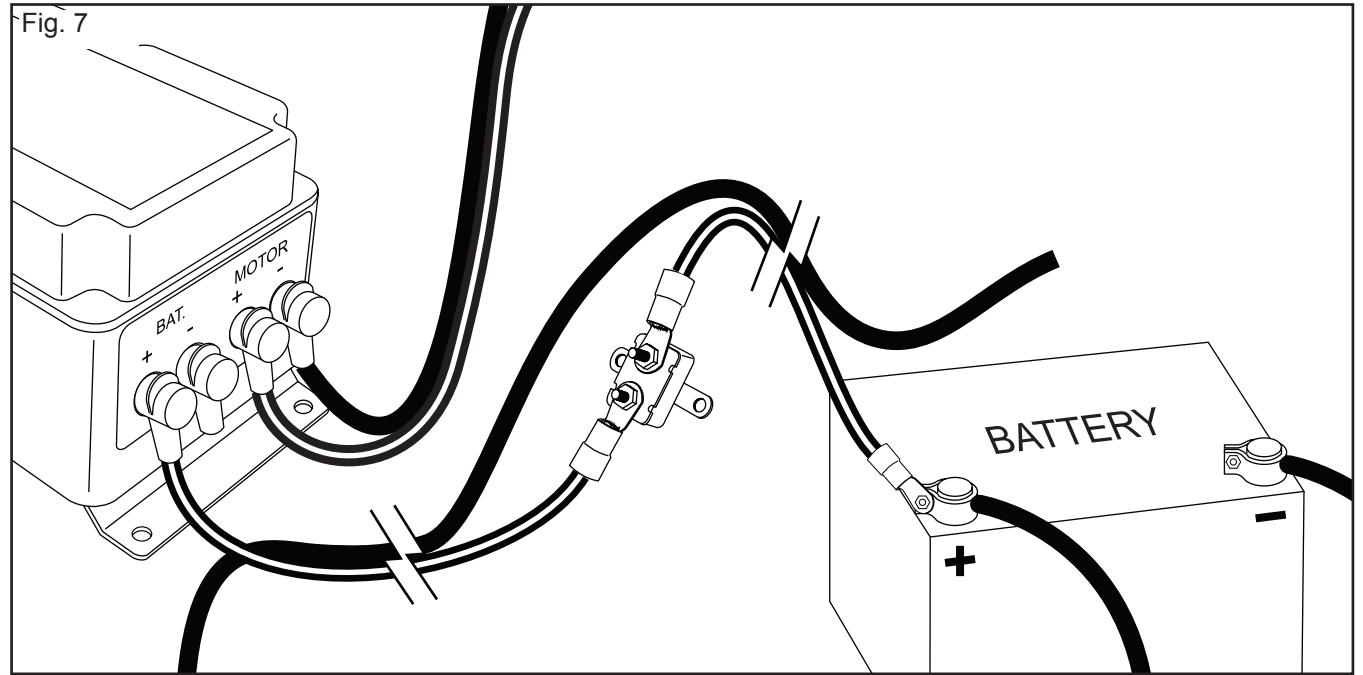

Step 6. Wiring the Battery

- A. Connect the black 6 ga. wire to the negative terminal on the battery using a 6 ga. 3/8" terminal end (part # 514-0309) or 1/4" terminal end (part # 514-0308) depending on the size of the terminal at the battery. (Fig. 8).
- B. Attach the other end of the black 6 ga. wire to BAT (-) at the control box as done in step 3. Slide Black Terminal Boot over the end and connect using the Lug Connector (part # 514-0308) as shown in Fig. 8.

Warning: You must attach the black 6 ga. wire to the battery first, before attaching it to the box.

Note: If the system operates backwards then reverse the 6 ga. wires on the motor.

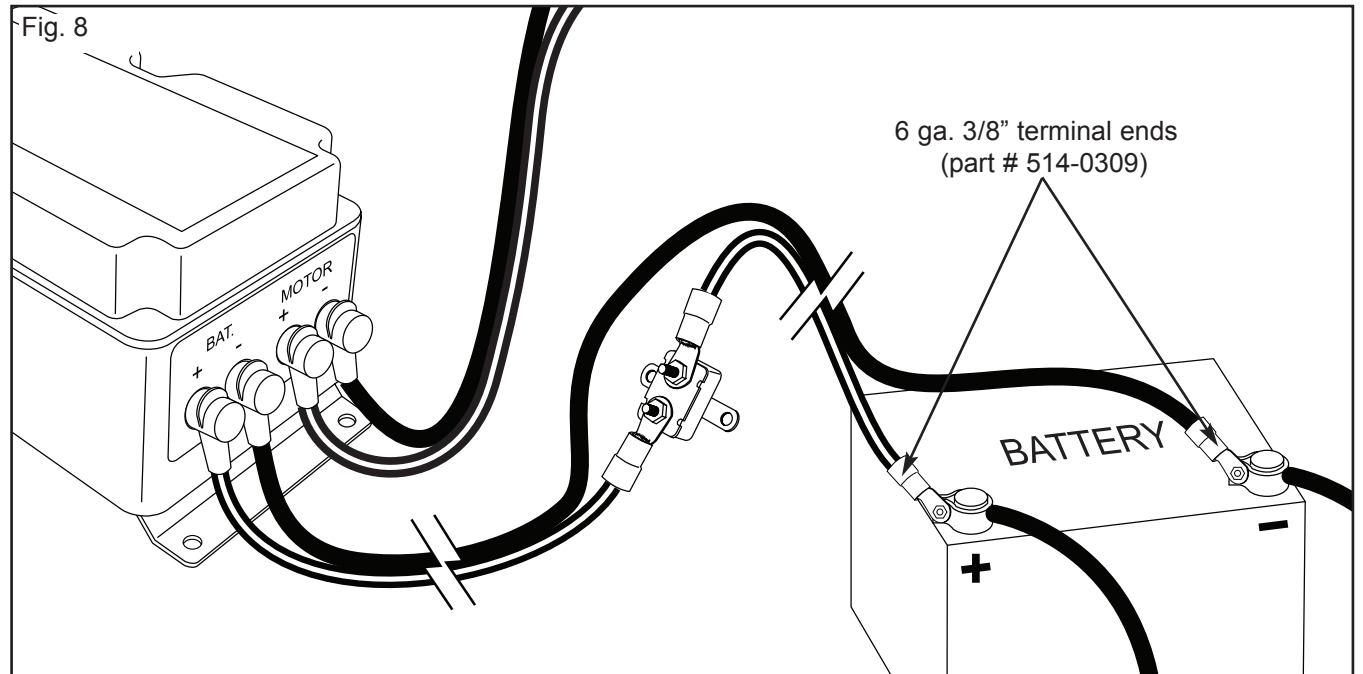

Smart Switch with External Switch - 12 Volt - (514-9953)

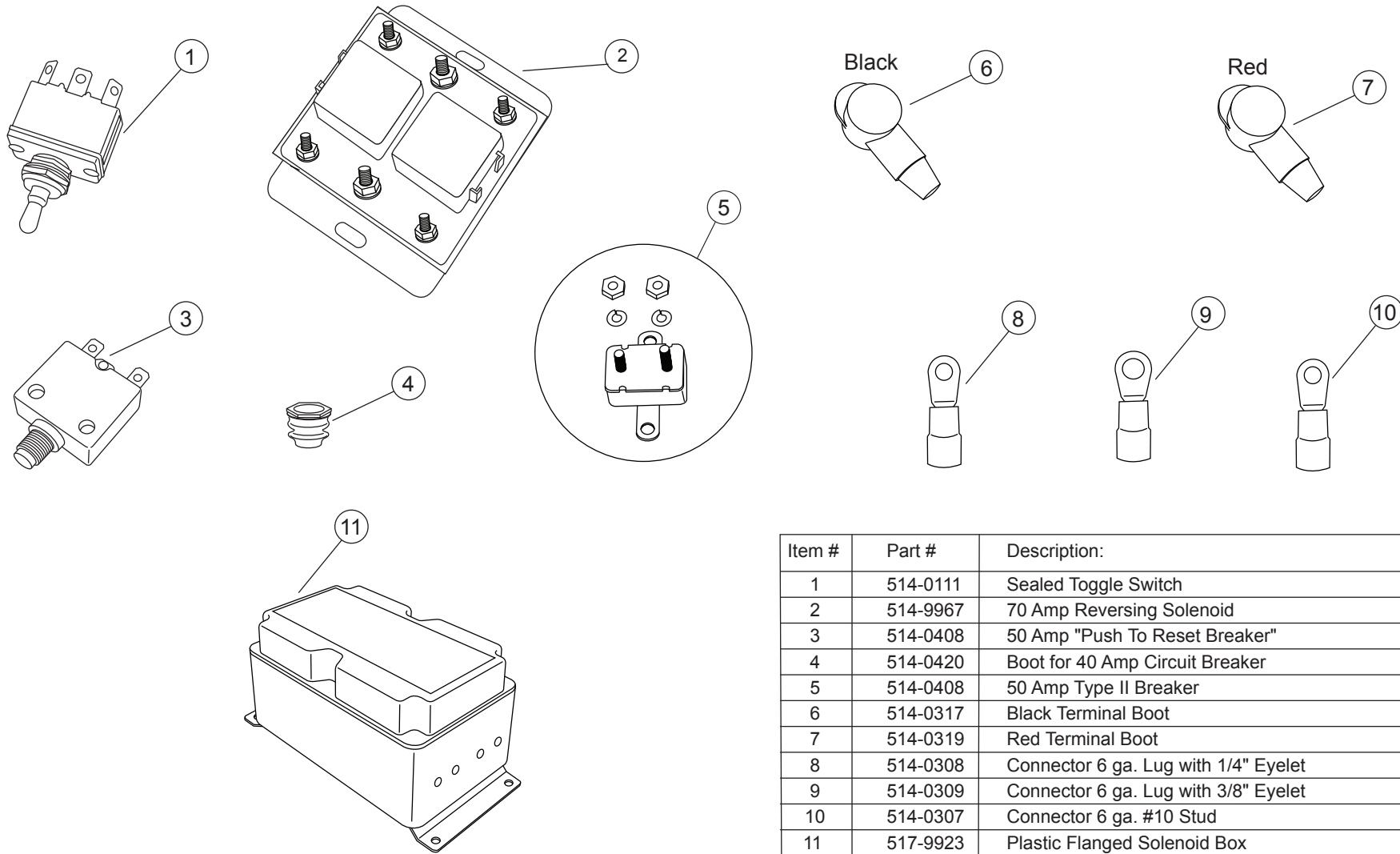

Item #	Part #	Description:	QTY:
1	514-0111	Sealed Toggle Switch	1
2	514-9967	70 Amp Reversing Solenoid	1
3	514-0408	50 Amp "Push To Reset Breaker"	1
4	514-0420	Boot for 40 Amp Circuit Breaker	1
5	514-0408	50 Amp Type II Breaker	1
6	514-0317	Black Terminal Boot	2
7	514-0319	Red Terminal Boot	2
8	514-0308	Connector 6 ga. Lug with 1/4" Eyelet	6
9	514-0309	Connector 6 ga. Lug with 3/8" Eyelet	2
10	514-0307	Connector 6 ga. #10 Stud	2
11	517-9923	Plastic Flanged Solenoid Box	

Motor check out procedure:

1. Remove leads from motor & attach volt meter to the leads.
2. With the switch in to on position, the volt meter should read 12 volts minimum. If voltage is low recheck with engine running. Recheck wiring and connections (minimum 6 gauge wire must be used.)
3. Return switch to the neutral position & reattach leads to motor.
4. Attach volt meter to leads at the motor.
5. With the switch in the on position and the leads attached, the volt meter should read 8.5 volts minimum. If voltage is low recheck with engine running. Recheck wiring and connections (minimum 6 gauge wire must be used).
6. Return switch to the neutral position and attach amp meter to leads at the motor.
7. With the switch in the on position, amp meter should read approximately 30 amps. Constant amperage reading of over 50 amps indicated binding in the system and/or low voltage.
8. Disconnect 6 ga #10 terminal end from the solenoid side of the breaker.
9. Connect the 6 ga #10 terminal end to the battery side of the breaker. This will bypass the breaker.
10. Test the tarp system. If the motor operates properly then replace the breaker.

