

Supplemental Instructions For Reliance Transfers

Front Box - Part # 501-0613

Step 1. Tarp Return Ramps

The Tarp Return Ramps (501-0309) should be centered to the peak on the tail gate arms and welded in place (Fig. 1)

Step 2. 1/2" Round Bar Stock

Tack Weld the 1/2" Round Bar Stock (501-0315) to the top edge of the angled deflector at the rear of the box and weld to the tarp return ramps on each end (Fig. 1). This provides a smooth surface for the tarp to slide on.

Step 3. Rope Centering Guide

Mark the center of the 1/2" Round Bar Stock and grind a smooth notch or heat dimple to provide a rope centering guide (Fig. 2 & 3). This is important because the diamond top rail makes it possible for the pullrod to fall into the box if the rope is not centered when pulling out or retracting the tarp.

Step 4. Grind Down Rough Edges

Some edges on the body are very sharp. Grind down any sharp edges so that the tarp will not get damaged when it is pulled over the body and tail gate.

Step 5. Reliance Hinge Ramp

This kit enables the Pullrod to roll up and over the arms and return without getting hung-up. First tack weld the pointed angled end of the Hinge Ramp (501-031X) to the angled front plate of the hinge assembly. Weld as high as possible but not on top of the arm (Fig 4). **DO NOT WELD GUSSET TO THE BOX.** The Hinge Ramp must be able to rotate freely inside the box as the arm lifts the tailgate.

Step 6. Re-install Tarp and Test

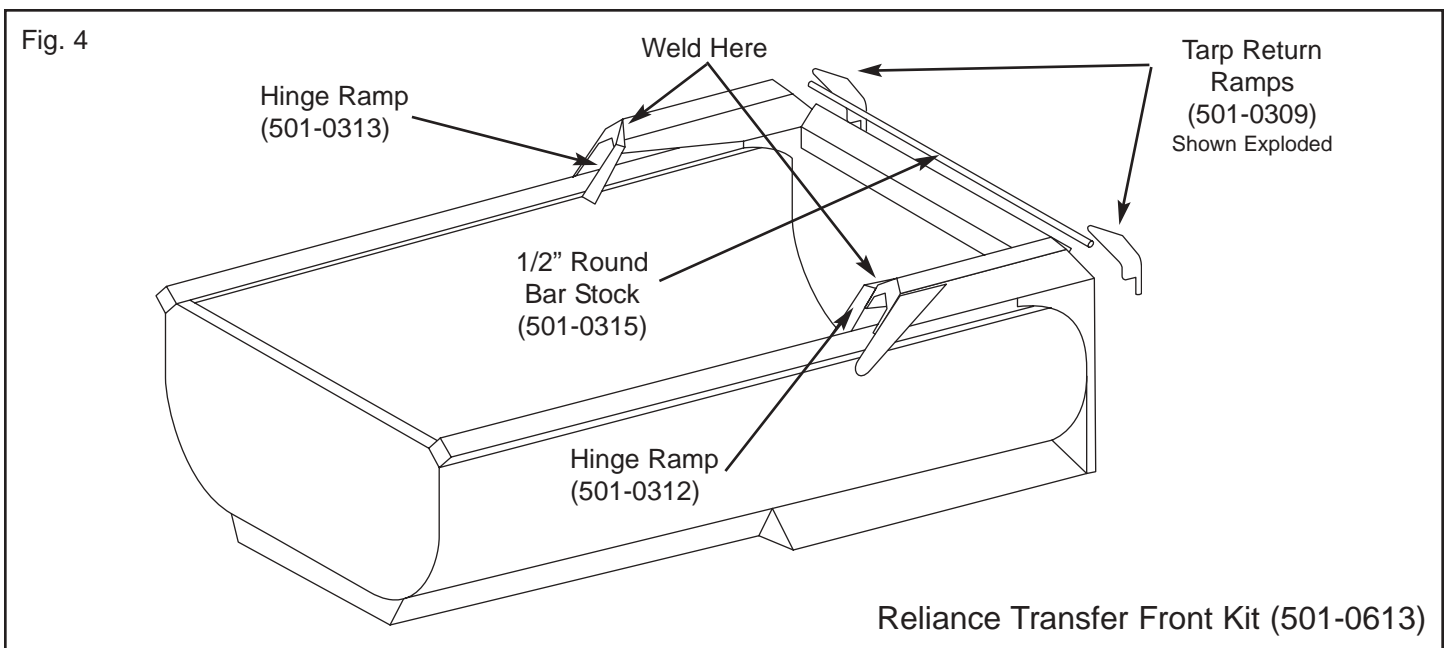
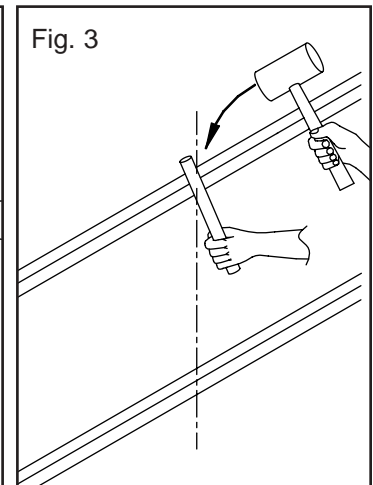
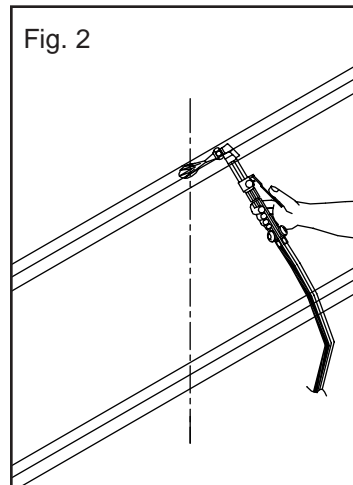
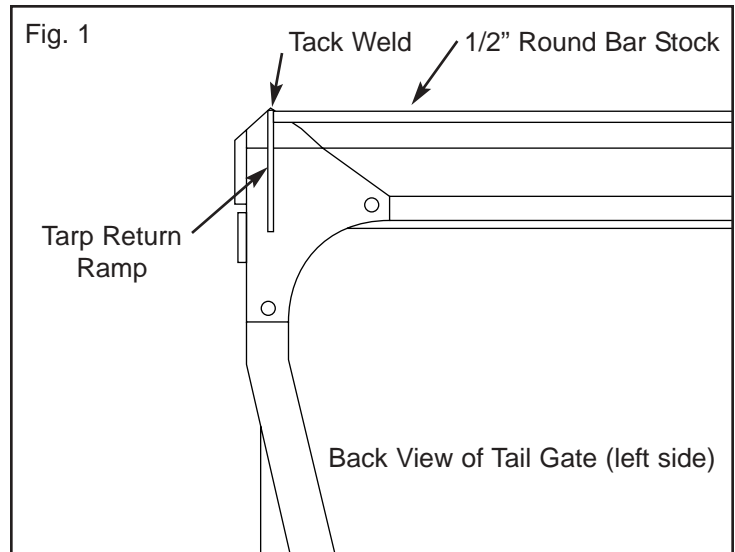

Reliance Transfer Front Kit (501-0613)