

NEW!
THE CLOSER

* Patent Pending

Super Slider

Super Slider... Simply The Best!

The Automatic Closer for Super Slider cable systems makes all other cable systems obsolete. This latest Pulltarps innovation automatically closes to seal off the load at the tailgate.

Here's how it works:

The spring loaded closer bow holds the tarp up above the load.

As the tarp is extended the closer bow follows the ramps down to automatically close off the rear of the tarp at the tailgate.

The closer is now locked down tight to seal off the load. The rear closer also forms at taper at the rear of the tarp for better aerodynamics and fuel economy.



The Super Slider's single cable design is what makes these systems the best. Having only one cable causes both sides of the bows to move evenly thereby eliminating jamming.

Our removable UHMW sliders allow you to replace a bow if one becomes damaged without removing the cable. The UHMW sliders wipe the top rail clean for extra smooth operation, plus they are guaranteed to never wear out.

Features and Benefits

- ▶ The New Rear Closer automatically closes off the tarp at the tailgate when the tarp is extended.
- ▶ The Closer eliminates the need to climb up on the rear of the trailer to tie a rear flap down.
- ▶ The Closer automatically locks down tight at the tailgate.
- ▶ The taper at the front and rear of the Super Slider with the Closer is more aerodynamic to save fuel.
- ▶ All parts are either aluminum or zinc plated for rust protection and better appearance.
- ▶ Tension the entire system with the turn of just one bolt at ground level.
- ▶ All bows are made from 1 1/8" galvanized steel. The galvanized steel provides protection against rust.
- ▶ Clean nice appearance because all the sliders and cables are hidden.

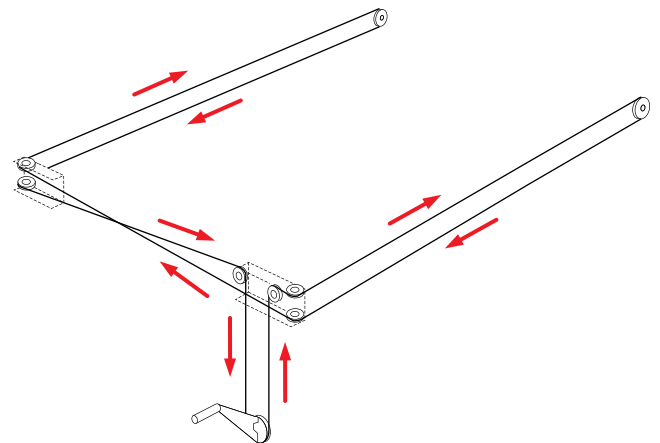

Single Cable Drive

- ▶ The single cable drive features one continuous cable that crosses in the front of the trailer.
- ▶ Because the rear drive bow is attached to the same cable it is impossible for the bows to jam or get out of time.