

Parts and Accessories



Automatic Rear Closer

Automatically closes off the tarp at the tailgate. Seals better than standard rear laps automatically. No more climbing up on your truck to bungee the rear flap.

*Patent Pending



Hand Cranks

The rotating handle folds out of the way. The special locking mechanism secures the tarp when it is extended or retracted.

Part # 502-0501
Part # 502-0502
with Idler (shown)



Electric Motor Drive

The 1.1hp Superwinch® motor is backed by a 3 year prorated manufacturer's warranty.

Part # 502-0601 (to 25')
Part # 502-0602 with Gear Drive
(over 25', shown)

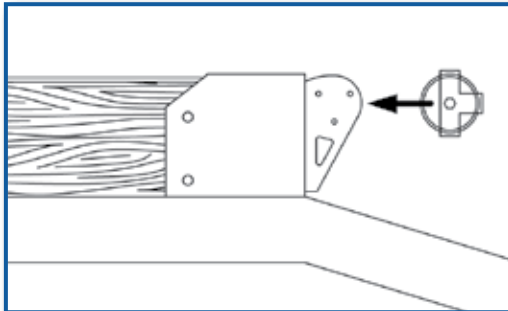

Belly Dump Rear Pulley Brackets

Used for mounting the rear pulleys to the back of a belly dump. Mounted flush against the rear board pocket so the tarp can cover the hopper completely.

Part # 502-0197 left
Part # 502-1101 right

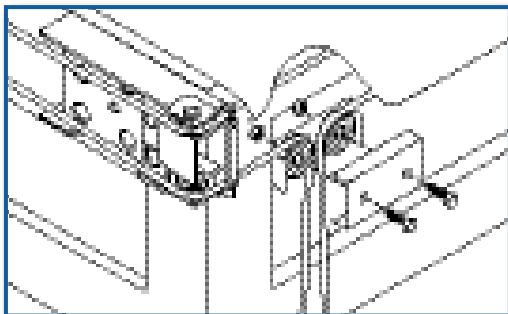

Side Pulley Box

Allows you to mount your electric drive or hand crank to the side of the body rather than the front.

Part # 502-0108

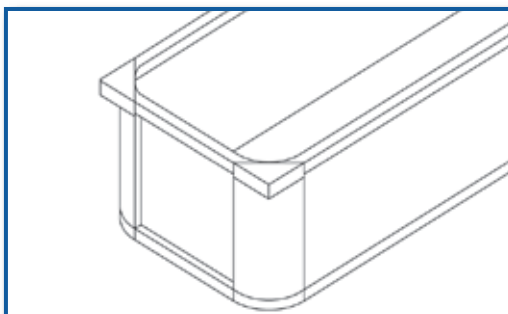

Front Corner Brackets

Allows you to mount your cable system to the front of a trailer that has radiused corners. The brackets can be either welded or bolted in place.

Part # 502-0132