

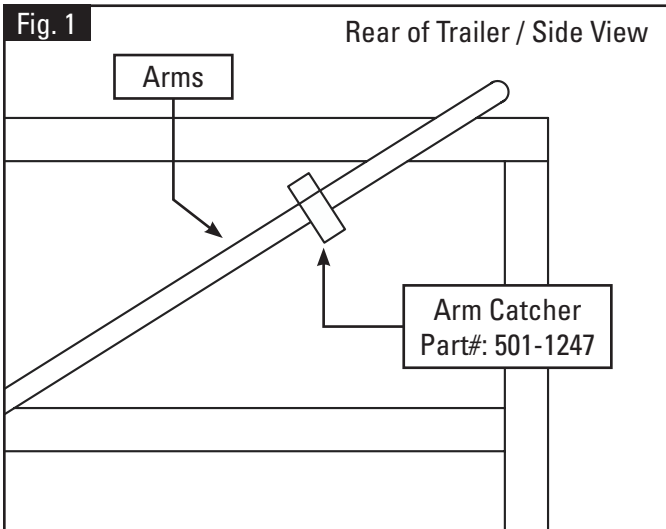

SUPPLEMENTAL INSTRUCTIONS

Arm Catcher for Automatic Arm Systems

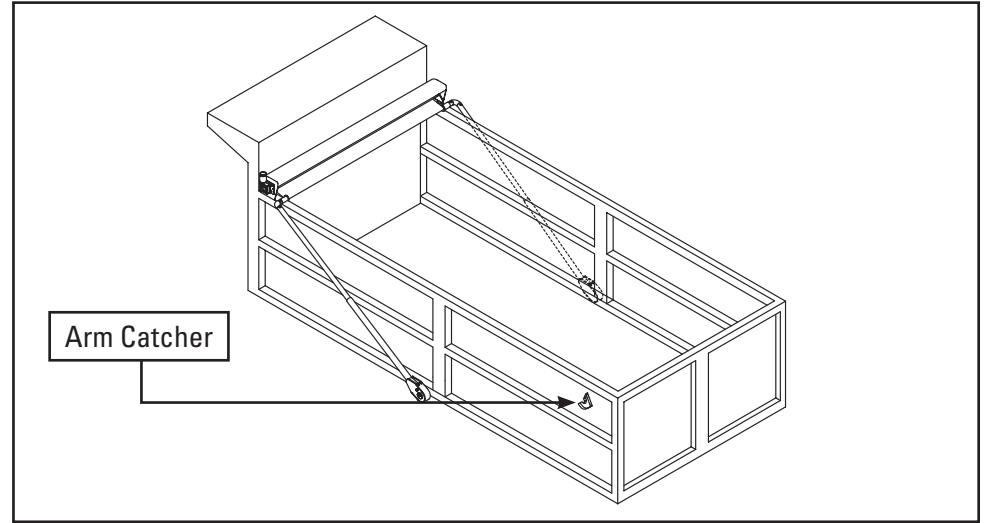
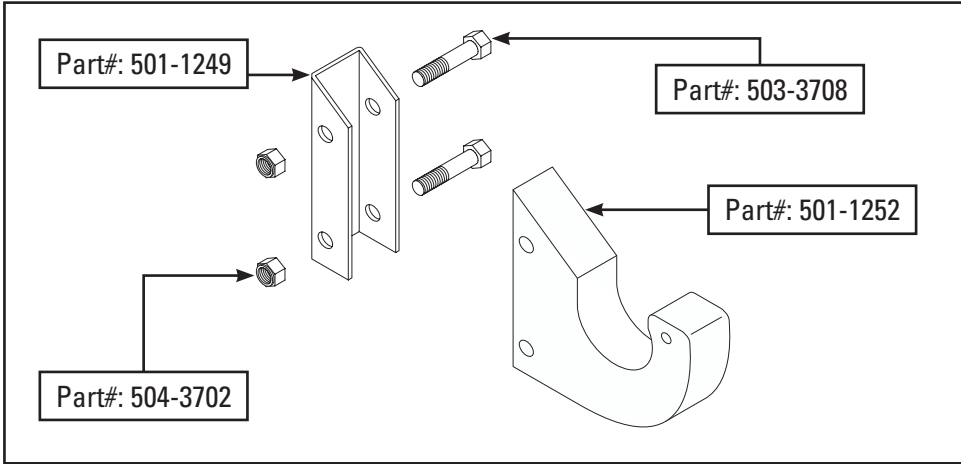

Step 1: Arm Catcher Installation

Extend the arms to the rear of the body. Clip Arm Catcher Assembly (part # 501-1247) to the arm tubing and position (Fig. 1). Mark the location of the mounting bracket on the body. Remove the Flush Mount Bracket (part # 501-1249) from the Arm Catcher and weld to the body in the marked location. Reattach Arm Catcher to Bracket after welds cool.

Note: Some installations may require fabricating a bracket to move the Arm Catcher Assembly farther out from the body (Fig. 2). The top part of the fabricated bracket must be at the same angle as the top of the Arm Catcher to guide the arms into place.

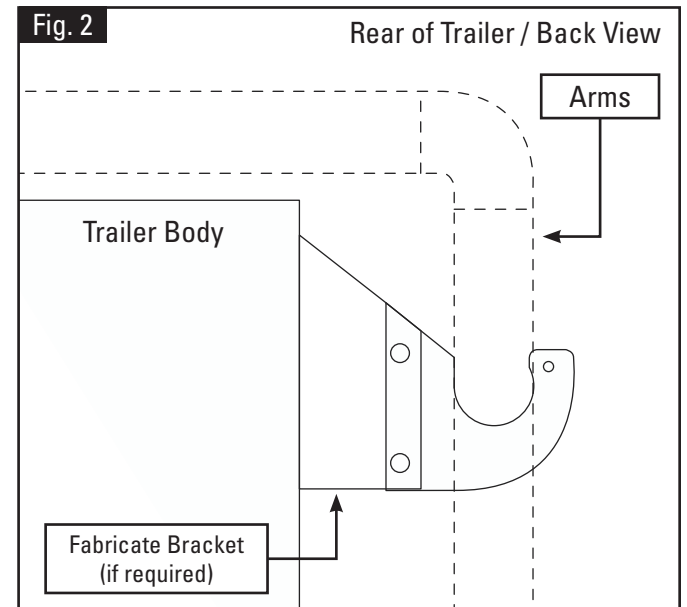

Document #: 607-0100
 Part #: 501-1247
 Revised: 03/13/23 WLH