



TROUBLE SHOOTING GUIDE

Automatic Arm Systems

Related Instructions,
How-To Videos & More



[PDF: Aluminator 7000E System](#)



[PDF: Aluminator 8500E](#)



[PDF: Automatic Systems - Arms up to 40'](#)



[PDF: Electric Core Systems](#)



[Video: SuperShield™ 9500E Operation](#)

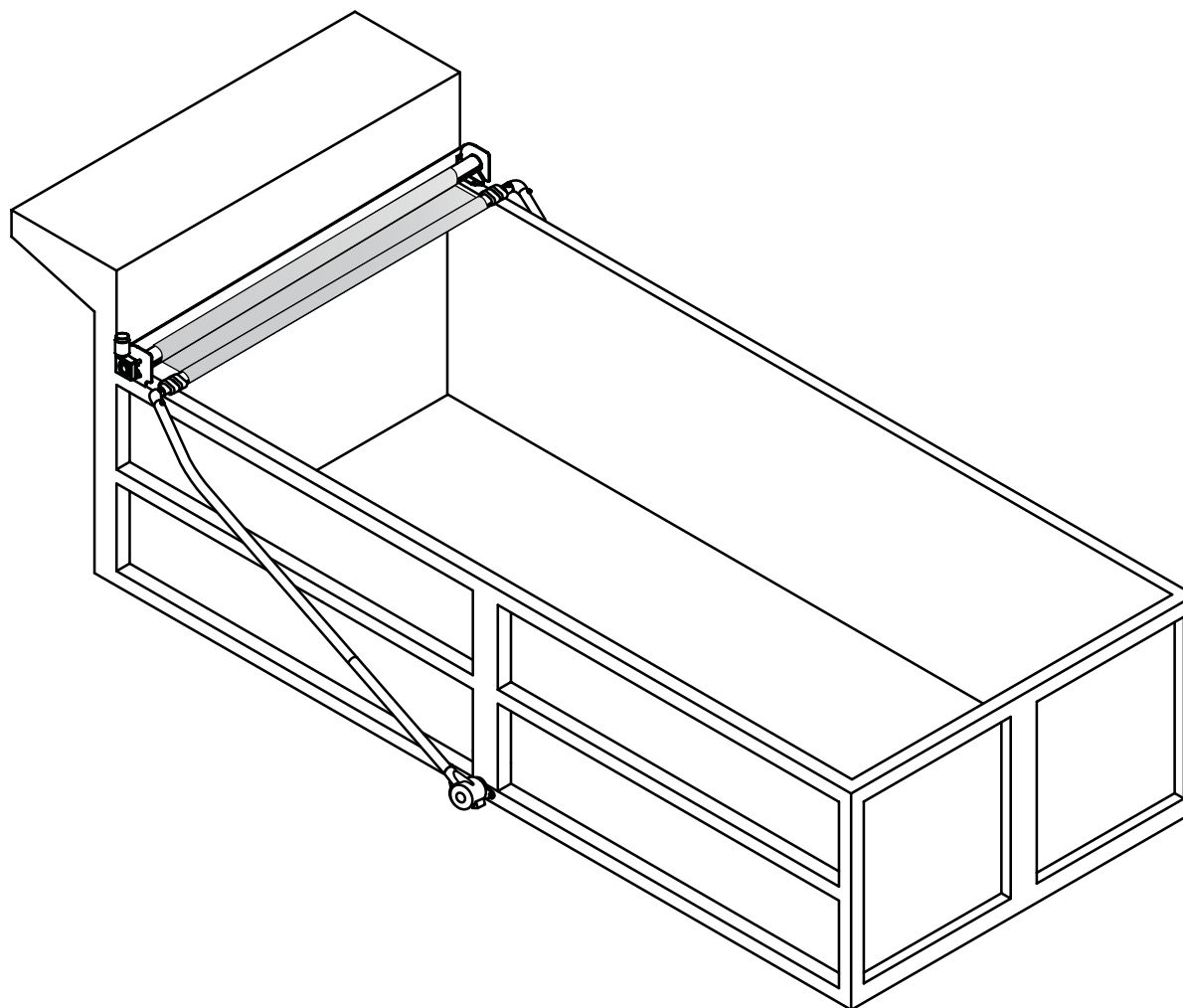

Revised: 01/12/26 WLH

CONTACT CUSTOMER SERVICE IF YOU NEED FURTHER ASSISTANCE



A Roll-Rite Brand



Table of Contents

Trouble Shooting Guide

Problem/Symptom/Cause/Solution 1-3

Motor Check Out Procedure 4





A Roll-Rite Brand



TROUBLE SHOOTING GUIDE

Automatic Arm Systems

PROBLEM	SYMPTOM	CAUSE	SOLUTION
Tarp will not fully extend.	Arms stall and tarp unrolls into bed.	Not enough spring tension. Spring not properly indexed at 180 degrees or 150 degrees (see instructions).	Re-index spring pivot per installation instructions.
		Spring has lost tension.	Check spring for breaks / damage and replace if needed.
		Spring is binding.	Clean spring and replace any worn or damaged parts.
			Check Pivots to make sure they are parallel to each other.
			For Single Spring Systems, check Pivot Bushings for wear and deforming.
	Arms stall in windy conditions.	Tarp is acting like a sail.	Reposition the vehicle heading into wind.





A Roll-Rite Brand



TROUBLE SHOOTING GUIDE

Automatic Arm Systems

PROBLEM	SYMPTOM	CAUSE	SOLUTION
Tarp will not fully retract.	Tarp does not roll up straight.	Pullbar is not square to the system.	Adjust arm length so that the Pullbar is square to the tailgate.
	Pullbar is square at the tailgate but not when the arms are retracted to the system.	Pivot points on each side of the box are not parrallel.	Relocate Pivots on each side of the bed so that they are parrallel (see instructions).
	Tarp does not roll up straight or walks off to one side.	Tarp is not square or Tarp is torn.	Repair or replace Tarp.
		Truck is not on a level surface.	Reposition truck.





TROUBLE SHOOTING GUIDE

Automatic Arm Systems

PROBLEM	SYMPTOM	CAUSE	SOLUTION
Tarp stops short of rolling up all the way.	Tie Downs or Side Flaps bind on the housing.	Tie Downs or Side Flaps are not being used properly.	Review operation of Side Flaps / Tie Downs to make sure that they are laying flat on the top of the tarp.
		Wrong size housing. Too much tarp fabric on the roller.	Replace with next size housing.
Motor will not turn or turns slowly.	Low voltage and/or low amperage at the motor.	Wrong gauge wire used.	6 gauge wire must be used from the power source to the motor.
		Low voltage supply to the motor.	Fully charge the battery and/or operate with the engine running. See motor check out procedure.
Arms do not extend evenly.	Arms and Pullbar go out of square to the box.	Spring indexing and/or spring tension is out of specs.	<p>Remove upper arm sections. Raise each Lower Arm section until the slack is just taken out of the Spring Pivot. The Arm must be lined up at 180 degrees or 150 degrees (see instructions). Re-index arm pivots as necessary.</p> <p>Next, attach a spring scale to the Lower Arm section. Raise the arm to height of 4" and read the scale.</p> <p>Readings between each side should be within 10% of each other.</p>



Motor Check Out Procedure (Fig. 1)

1. Remove leads from motor & attach volt meter to the leads.
2. With the switch in to on position, the volt meter should read 12 volts minimum. If voltage is low recheck with engine running. Recheck wiring and connections (minimum 6 gauge wire must be used).
3. Return switch to the neutral position & reattach leads to motor.
4. Attach volt meter to leads at the motor.
5. With the switch in the on position and the leads attached, the volt meter should read 8.5 volts minimum. If voltage is low recheck with engine running.
6. Recheck wiring and connections (minimum 6 gauge wire must be used).
7. Return switch to the neutral position and attach amp meter to leads at the motor.
8. With the switch in the on position, amp meter should read approximately 30 amps. Constant amperage reading of over 50 amps indicated binding in the system and/or low voltage.
9. Disconnect 6 ga. 1/4" terminal end from the solenoid side of the breaker.
10. Connect the 6 ga. 1/4" terminal end to the battery side of the breaker. This will bypass the breaker.
11. Test the tarp system. If the motor operates properly then replace the breaker.

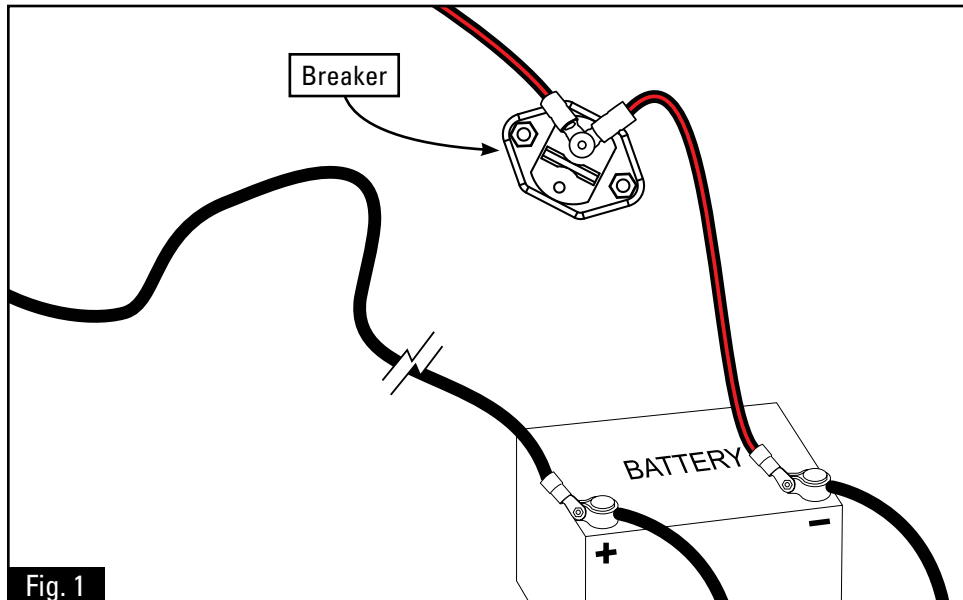

Fig. 1