



A Safe Fleet Brand



Installation Instructions

Smart Switch Basic Kit - 12 Volt

514-0114

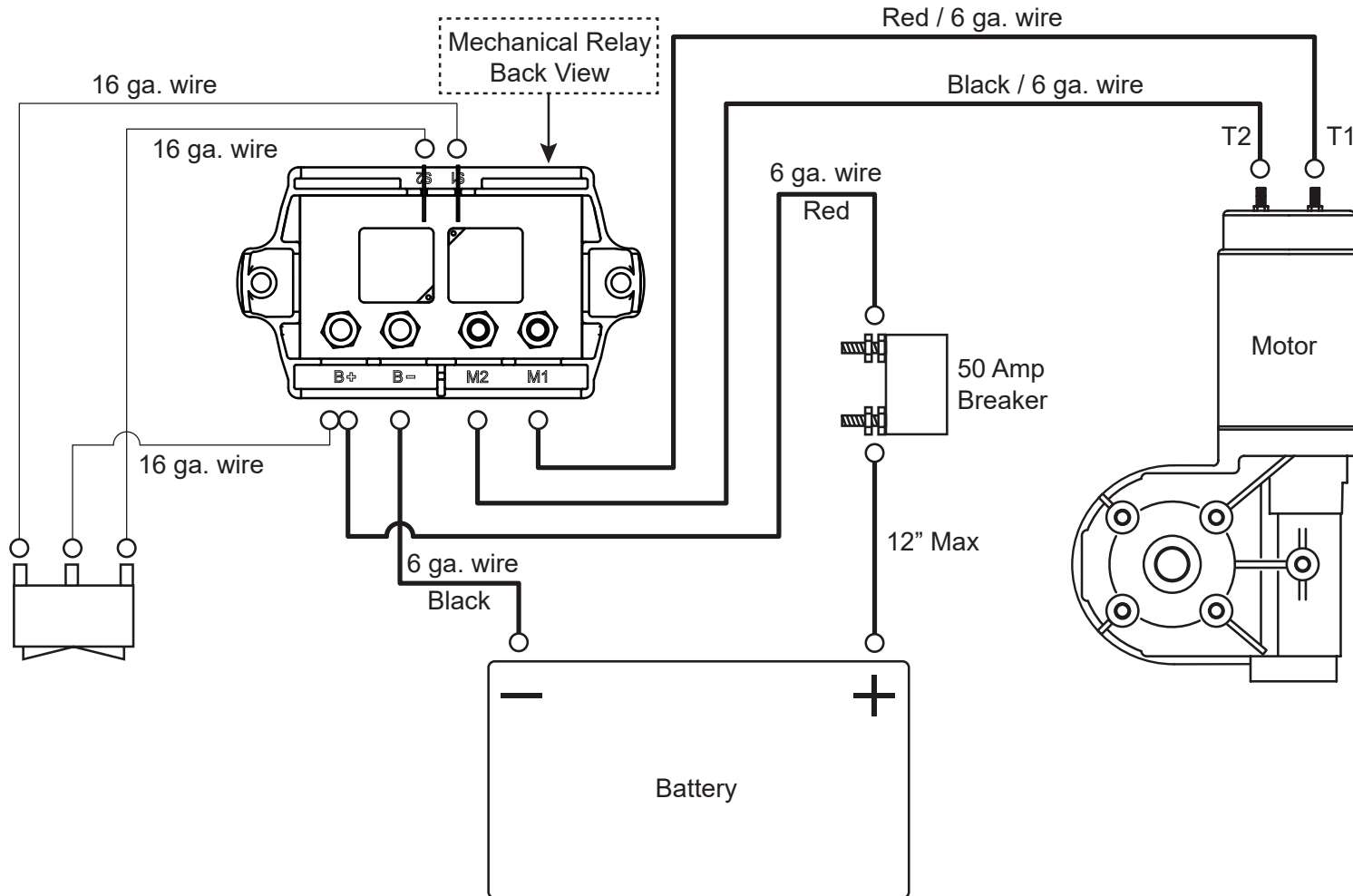

607-0089

WLH 07/11/19



A Safe Fleet Brand



**Installation Instructions**

**Smart Switch Basic Kit - 12 Volt**

**TABLE OF CONTENTS**

**Safety, Tools & System Requirements**

**Diagrams & Parts**

Safety Requirements / Tools and Equipment Required for Installation ..... 2

Vehicle Battery Connection Requirements / Mechanical Reversing Relay Requirements (Part # 514-9978) ..... 3-4

Switch Requirements / Gear Motor Installation Requirements .. 5

Smart Switch Basic Kit - Wiring Diagram #514-0114 ..... 13

Smart Switch Basic Kit #514-0114 ..... 14

**Installation Instructions**

Wiring the Motor ..... 7

Wiring the Smart Switch ..... 8-10

Wiring the Battery ..... 11



A Safe Fleet Brand

A large, light gray warning sign graphic consisting of a triangle with a white exclamation mark inside, centered behind the main title text.

# SAFETY, TOOLS & SYSTEM REQUIREMENTS



A Safe Fleet Brand



## Safety Requirements



***Failure to comply with requirements outlined in this document may result in serious injury or property damage.***

The following requirements shall be met when installing or servicing electrical components in Pulltarps Automated Tarp Systems:

- All connections to vehicle battery systems, vehicle battery chargers, and external power supplies shall be disconnected during all installation procedures.
- Prior to installing wiring on positive terminals, check voltage on all wires and connection points using a voltmeter.
- The following personal protective equipment shall be worn at all times while installing components:
  - » Safety Glasses or Prescription Glasses with Side Shields.
  - » Steel or Composite Toe Protective Shoes.

## Tools and Equipment Required for Installation

The following tools are required for installation of electrical components

- Torque Wrench with range between 50 to 150 in.lb.
- Nut Driver Set.
- Wire Cutters up to 2AWG size wire.
- Wire Insulation Stripping Tool for wire size range from 2 to 8 AWG.
- Wire Insulation Stripping Tool for wire size range from 16 to 18 AWG.
- Wire Terminal Crimping Tool for wire size range from 2 to 8 AWG.
- Wire Terminal Crimping Tool for wire size range from 16 to 18 AWG.
- Heat Gun for application of heat shrink insulation.
- Multi-meter with DC voltage measurement capability.
- Zip Ties.
- Vehicle Chassis Wiring insulated c-clamps capable of carrying 2 to 8 AWG wiring.



A Safe Fleet Brand



## Vehicle Battery Connection Requirements

### Main Power to Pulltarps System

- Source Voltage Line to Motor Reversing Relay shall be connected directly to the vehicle battery system.
- The Source Voltage Line shall include an in-line Pulltarps supplied circuit breaker. The circuit breaker shall be no greater than 12 inches from the positive terminal of the vehicle battery system.
- Main Power and Ground Connection through a power distribution box are forbidden.

### Main Ground to the Pulltarps System

- Ground line to the Motor Reversing Relay shall be connected directly to the negative terminal of the vehicle battery system.
- Battery terminals shall be coated with dielectric grease to prevent corrosion.
- Appropriate ring terminal or battery terminal at the vehicle battery connection are required.

### System Circuit Breaker Requirements

- The breaker shall be installed on the main positive wire within 12 inches of the positive terminal of the vehicle battery system.
- Circuit Breaker shall be mounted on a vertical surface with the input and output wires entering and exiting from the sides. This is the only approved installation orientation for the circuit breaker.
- Terminals of the circuit breaker shall be no less than 2 inches from any surface on the vehicle in all directions.

### Motor Reversing Relay Requirements



***Failure to properly follow all requirements may result in present or future property damage. Pulltarps Motor Reversing Relays contain a hot at all times connection to the vehicle battery system. Care must be taken to prevent contact between battery supply terminals and conductive surfaces of the chassis***



A Safe Fleet Brand



Motor Reversing Relay Requirements (Continued)



*The positive terminal of Pulltarps Motor Reversing Relay is hot at all times, breaker connected to the positive terminal of the vehicle battery energy system. Care must be taken to ensure the positive terminals meet the following:*

- 1. Connected only with the supplied fasteners to the correct torque (8-11 ft.lb) to prevent a loose, highresistance connection, and...*
- 2. Strain relieved to prevent wire torque and vibration from loosening connection.*
- 3. Completely covered with the proper Red terminal boot.*

*Failure to comply may result in excessive heat in the connection due to high resistance.*

**Mechanical Reversing Relay Requirements (Part Number 514-9978)**

- The Motor Reversing Relay shall be installed on a vertical plane with the wires from terminals (B+, B-, M2, M1) facing down. This is the only approved orientation of the motor reversing relay.
- Mount the relay in a location that it is protected from road debris, ice, snow, and road spray or bombardment.
- Use the terminal boots supplied with the motor reversing relay, according to the following color codes:
  - » B+ is RED indicating the terminal is un-switched, fused, and hot at all times.
  - » B- is Black.
  - » M2 is Black.
  - » M1 is Red.
- All terminals shall be coated with dielectric grease to prevent corrosion and long term connection from debris between electrical terminals.
- Install the motor reversing relay such that the terminals are facing the vertical mounting surface on the vehicle body
- The motor reversing relay shall be attached to the surface using only threaded fasteners with torque specification consistent with the fastener size and type.
- All terminal wires shall be strain relieved using insulated C-clamps attached to vehicle body to prevent wire vibration and torque loading from loosening electrical connections.
- Route all electrical wires from the Motor Reversing Relay in a manner that will avoid wire insulation chafing, pinching, and wear from other items on the truck chassis or wear from the environment.
- Torque all electrical connection fasteners to minimum 8-11 ft.lb.



A Safe Fleet Brand



## Switch Requirements

### Momentary Rocker Switch and Rotary Switch



*Pulltarps Rocker and Rotary switches contain hot-at-all-times connection at the center terminal of the switch. No exterior installation of the rocker or rotary switch is permitted. Contamination from an outside environment may connect the switch center input to the command line, resulting in unexpected movement of the tarp system.*

- Use only a Pulltarps supplied Rocker Switch or Rotary Switch with the motor reversing relay.
- Switch terminals shall be protected from contact with conductive materials.
- Switch harness shall be fully insulated.
- Switch spade terminal connections shall be fully seated, preventing exposed conductive surfaces.
- Rocker switch shall be installed such that the switch labels read from left to right.

## Gear Motor Installation Requirements

- Gear Motor shall be mounted using all mounting locations provided.
- Electric Motor connections shall be fully coated in dielectric grease.
- Electric motor connection torque requirement: 15 to 22 in.lb.
- To prevent terminal damage - **Do not exceed 25.5 in.lb.**



A Safe Fleet Brand







A Safe Fleet Brand



## Installation Instructions

Smart Switch Basic Kit - 12 Volt

### Wiring the Motor

#### Step 1.

Run the 6 ga. wire to both locations (motor & battery box) and attach to truck body (Fig. 1).

**Note:** The wire must go beyond the pivot point.

**Caution:** Make sure wire does not get pinched at the pivot.

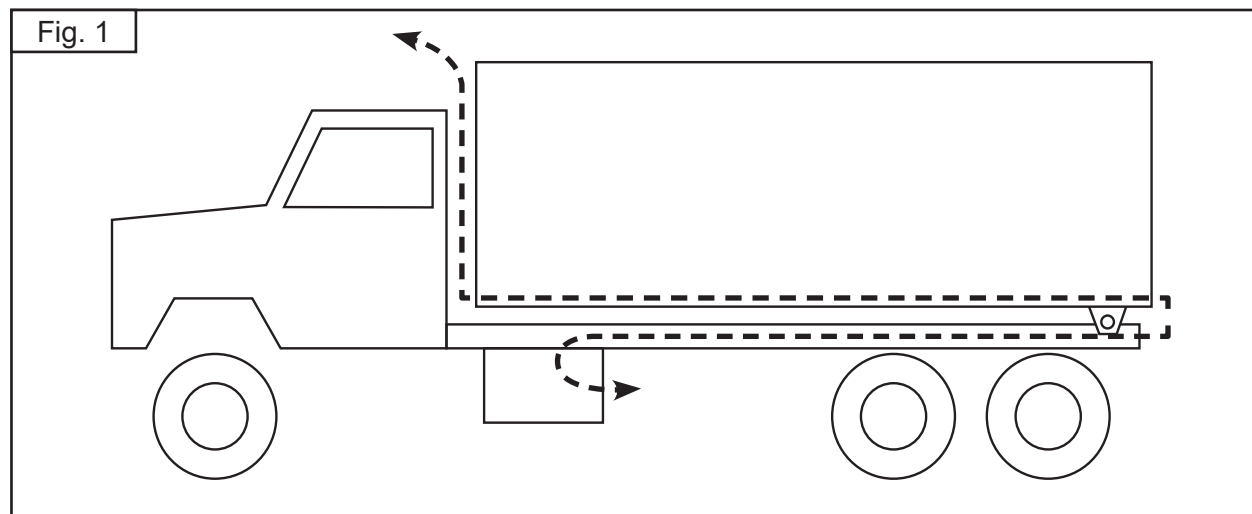

Split about 4" back

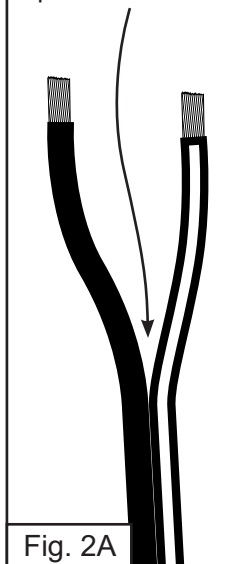

6 ga. 1/4" Lug Connector (part # 514-0308)

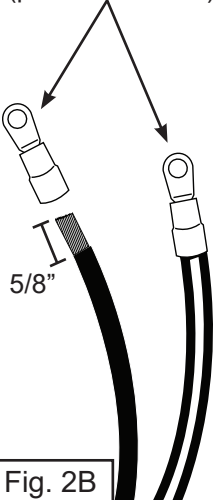

#### Step 2. Preparing the Connectors

On the motor side, split the molded 6 ga. wire approximately 4" (Fig 2A) and strip the ends about 5/8" down. Then attach connectors (part # 514-0308) and crimp (Fig. 2B).

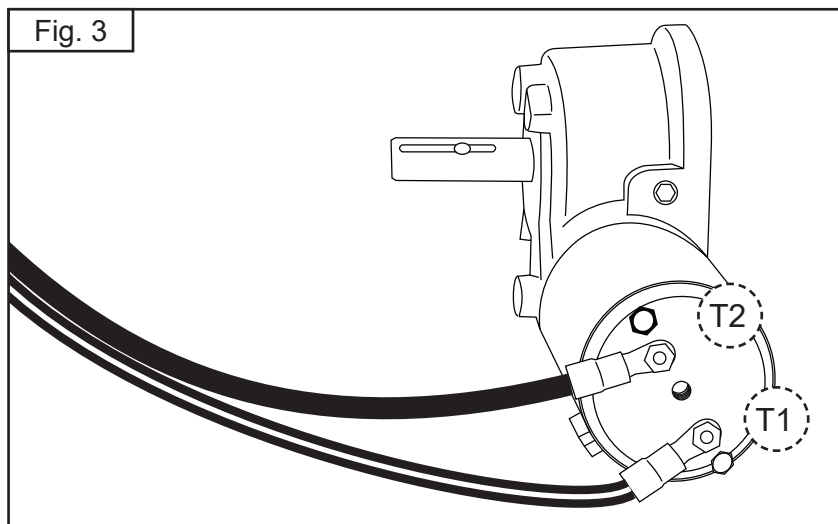

#### Step 3. Attaching Connectors to the motor

Attach Red wire to Terminal #1 on motor. Then attach the Black striped wire to Terminal #2 on motor (Fig. 3).



## Installation Instructions

## Smart Switch Basic Kit - 12 Volt

### Wiring the Smart Switch

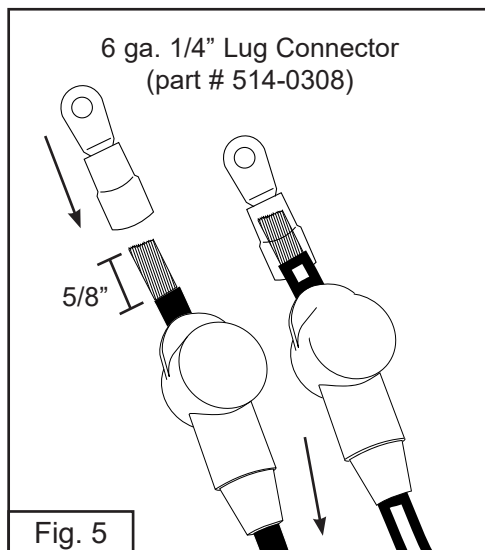
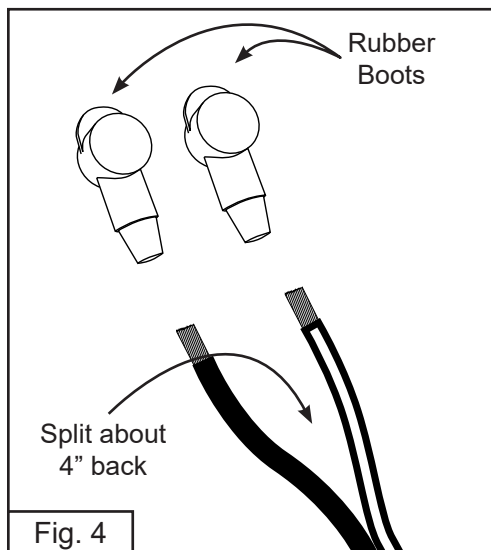

#### Step 4: Prepping the Wire

Take the other end of the wire and Split the 6 ga. wire at the control box about 4" back and slip on rubber boots - Red Boot (part # 514-0319) on Red striped wire and Black Boot (part # 514-0317) on black wire (Fig. 4).

Strip wire about 5/8" and attach connectors (part # 514-0308) (Fig. 4). Crimp Connectors (Fig. 5).

**Note: Do not over tighten nuts on connections!**

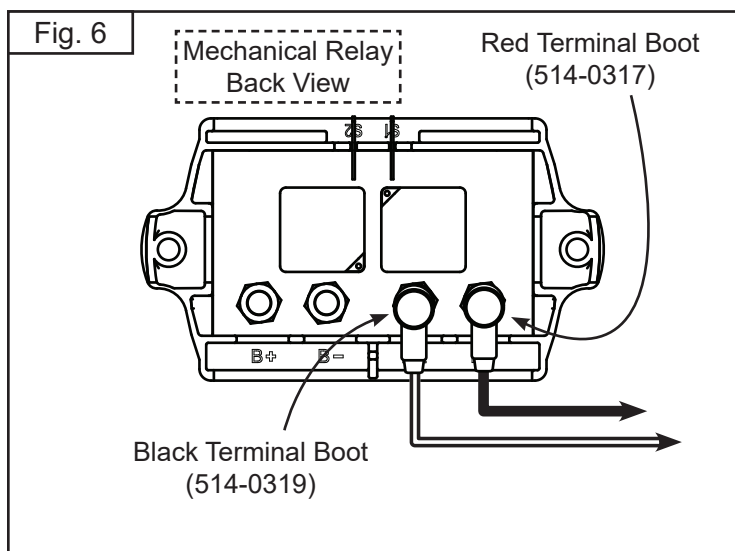

#### Step 5: Attaching the Connectors

Attach Red striped wire to the connector (M1) and connect the Black wire to Control Box (M2) (Fig. 6).

**Note: Both wires lead to the motor.**



## Installation Instructions

## Smart Switch Basic Kit - 12 Volt

### Wiring the Smart Switch

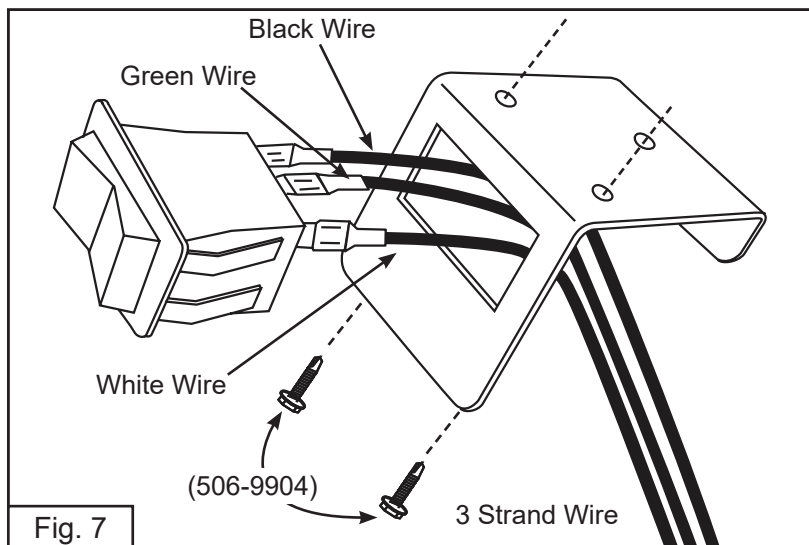

#### Step 6: Wiring 16ga. Wire to Cab from Solenoid

Mount Switch Bracket (part # 514-9954) in a convenient place in cab using the two self drilling screws (part # 506-9904).

Strip wire in cab about 1/4" and attach push on connectors (part # 514-0321) and crimp (Fig. 7).

Pull wire through Switch Bracket (part # 514-9954) (Fig. 7).

Attach wire to Rocker Switch (part # 514-0117) (Fig. 7).

- Green to Center
- Black to Top
- White to Bottom

Snap Rocker Switch firmly in Switch Bracket.

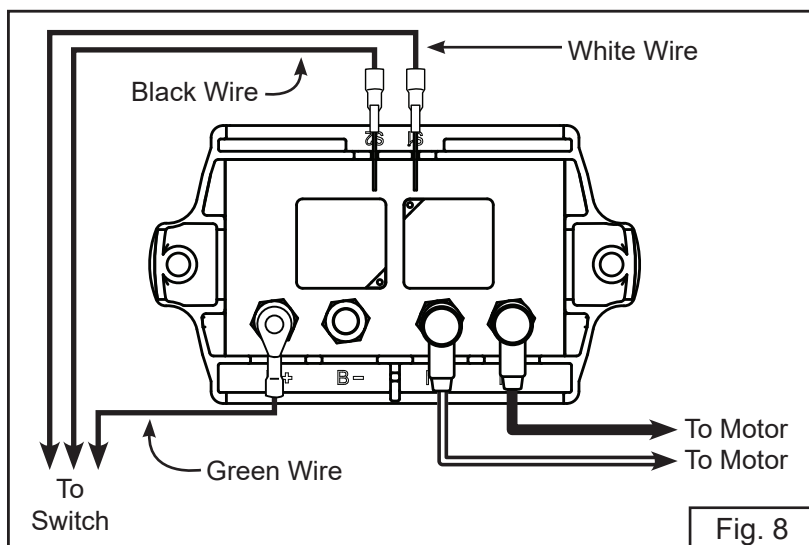

#### Step 7: Attaching Switch Wires to Solenoid

On the Green wire only, strip ends about 1/4" and attach 5/16" 14ga. loop connectors (part # 514-0303).

On the Black & White wires, strip end about 1/4" and attach connector with 1/4" Spade (part # 514-0321).

Attach White to S1 Male Terminal on Solenoid (Fig. 8).

Attach Black to S2 Male Terminal on Solenoid (Fig. 8).

Attach Green to B+ on Solenoid (Fig. 8).



### Wiring the Smart Switch

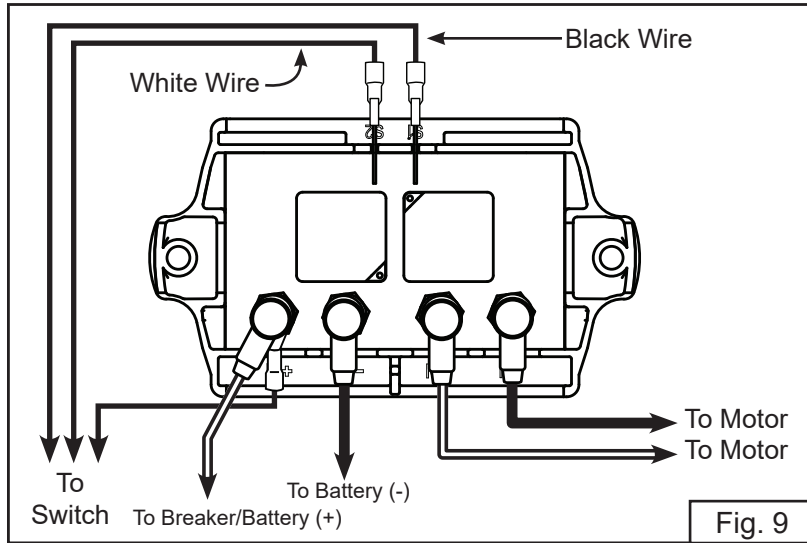

#### Step 8: Connecting the Solenoid to the Battery

Cut a length of wire to run between the battery and the solenoid.

Split wire about 4" down and strip ends about 5/8". Slip on Red Boot (part # 514-0317) on Red Striped Wire and Black Boot (part # 514-0319) on Black Wire as done in Step 4.

Attach Connectors (part # 514-0328) 6 Ga. 5/16" Lug and crimp to wires.

Attach Red Striped wire to B+ on Solenoid, and tighten nut (Fig. 9).

DO NOT attach Black wire to B- on Solenoid at this time.

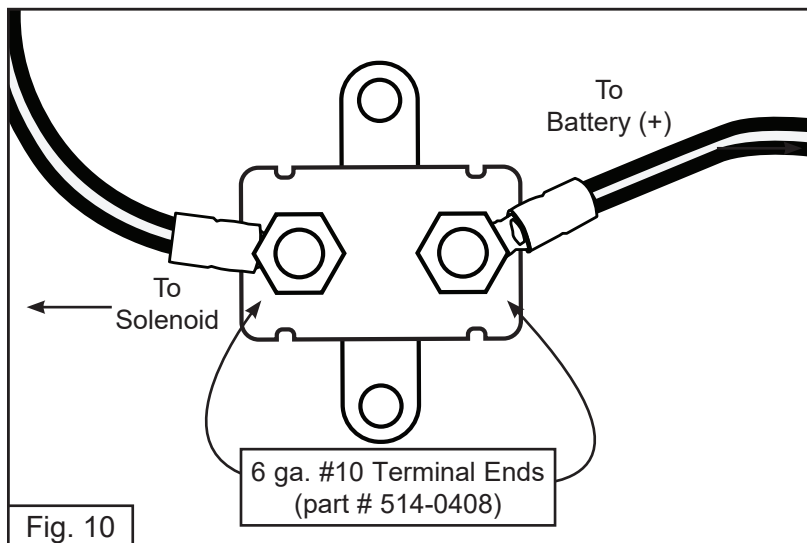

#### Step 9: Hooking up the Breaker

Mount the Breaker in the Battery Box within 12" of Battery, away from moisture, so that it won't short out on the battery lid or terminals (Fig. 10).

Split a section of the 6 ga. wire that runs from BATT+ on the Solenoid to the Breaker as needed.

Cut and then strip ends of the Red Striped Wire about 5/8" and attach the #10 terminal ends (Part # 514-0408) only to the Red Striped Wire.

Attach to Breaker. The breaker is marked "Load" at the Solenoid end and "Line" at the Battery end.

**Warning: Failure to install properly will void warranty on motor and other parts.**



### Wiring the Battery

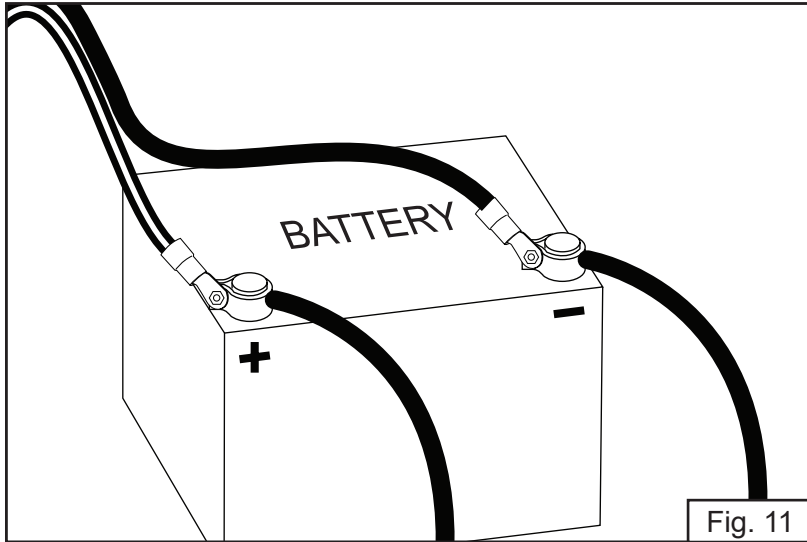

#### Step 10: Connecting the Solenoid to the Battery (Fig. 11)

Split the 6 ga. wire that runs from B+ and B- on the Solenoid about 4".

Strip the ends about 5/8" and attach the 3/8" connectors (part # 514-0309), crimp to wires.

Attach Red Striped wire to Positive Terminal on Battery.

Attach Black wire to Negative Terminal on Battery.

Note: If the system operates backwards, reverse the connections on the motor.



A Safe Fleet Brand

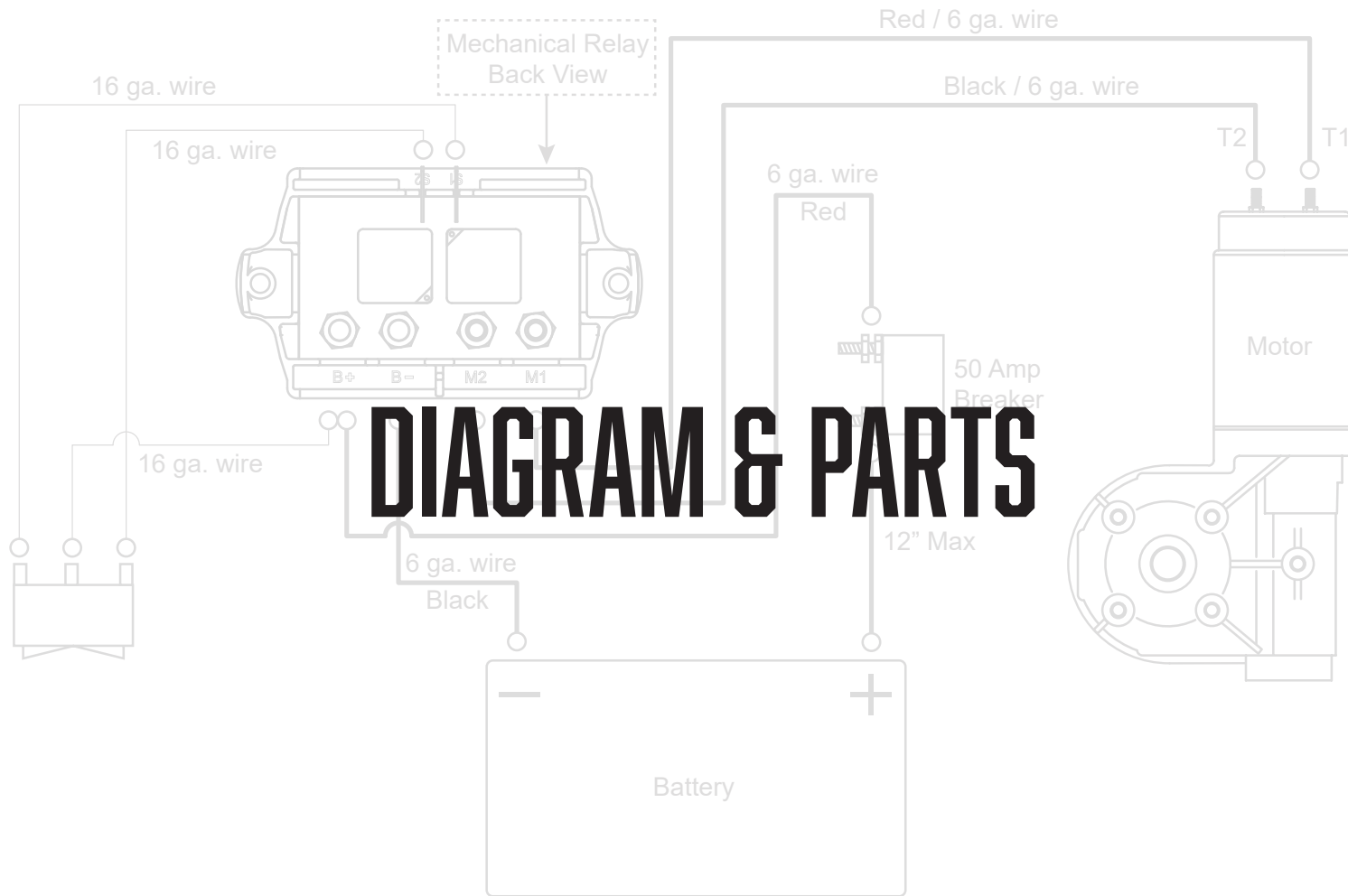

# DIAGRAM & PARTS



### Smart Switch Basic Kit - Wiring Diagram #514-0114

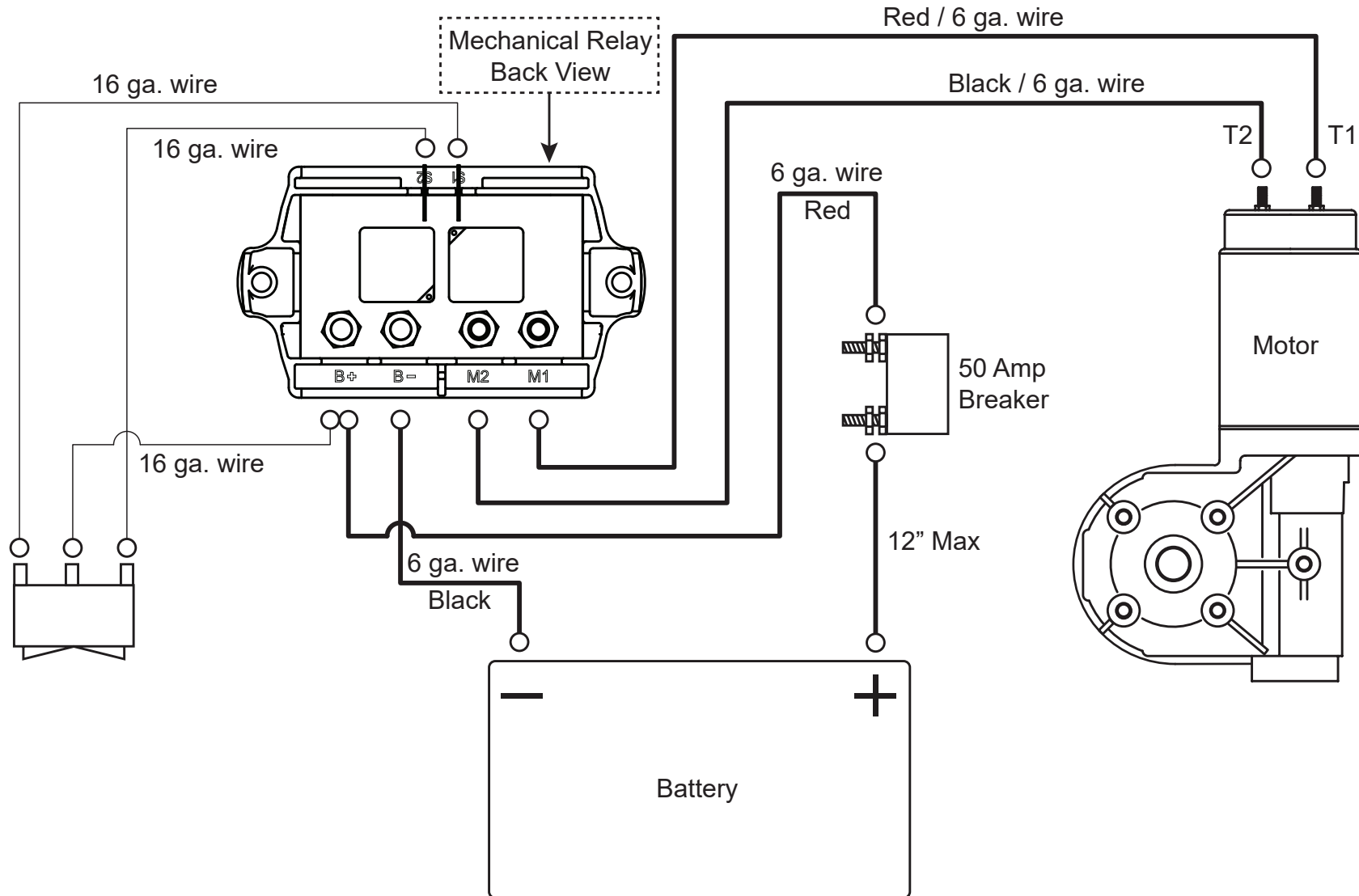



A Safe Fleet Brand



**Installation Instructions**

**Smart Switch Basic Kit - 12 Volt**

**Smart Switch Basic Kit #514-0114**

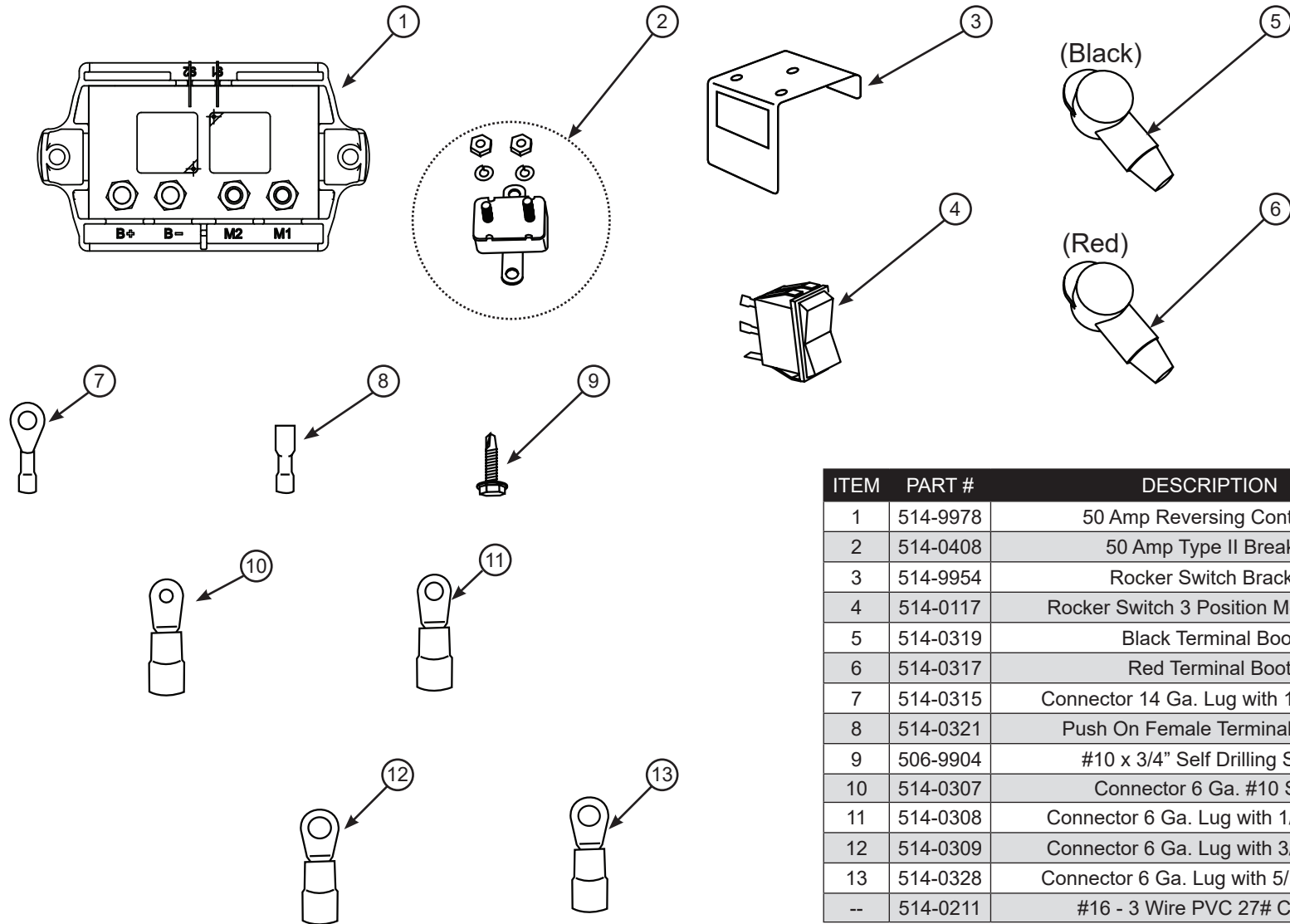

ITEM	PART #	DESCRIPTION	QTY
1	514-9978	50 Amp Reversing Contactor	1
2	514-0408	50 Amp Type II Breaker	1
3	514-9954	Rocker Switch Bracket	1
4	514-0117	Rocker Switch 3 Position Momentary	1
5	514-0319	Black Terminal Boot	2
6	514-0317	Red Terminal Boot	2
7	514-0315	Connector 14 Ga. Lug with 1/4" Eyelet	1
8	514-0321	Push On Female Terminal 16 Ga.	5
9	506-9904	#10 x 3/4" Self Drilling Screw	4
10	514-0307	Connector 6 Ga. #10 Stud	2
11	514-0308	Connector 6 Ga. Lug with 1/4" Eyelet	4
12	514-0309	Connector 6 Ga. Lug with 3/8" Eyelet	2
13	514-0328	Connector 6 Ga. Lug with 5/16" Eyelet	2
--	514-0211	#16 - 3 Wire PVC 27# Copper	25'

REV. 07/09/19 WLH