

40 Amp Electrical Switch Assembly Enclosed - (514-0105) Pre-Wired Weatherproof Switch

Wiring Instructions

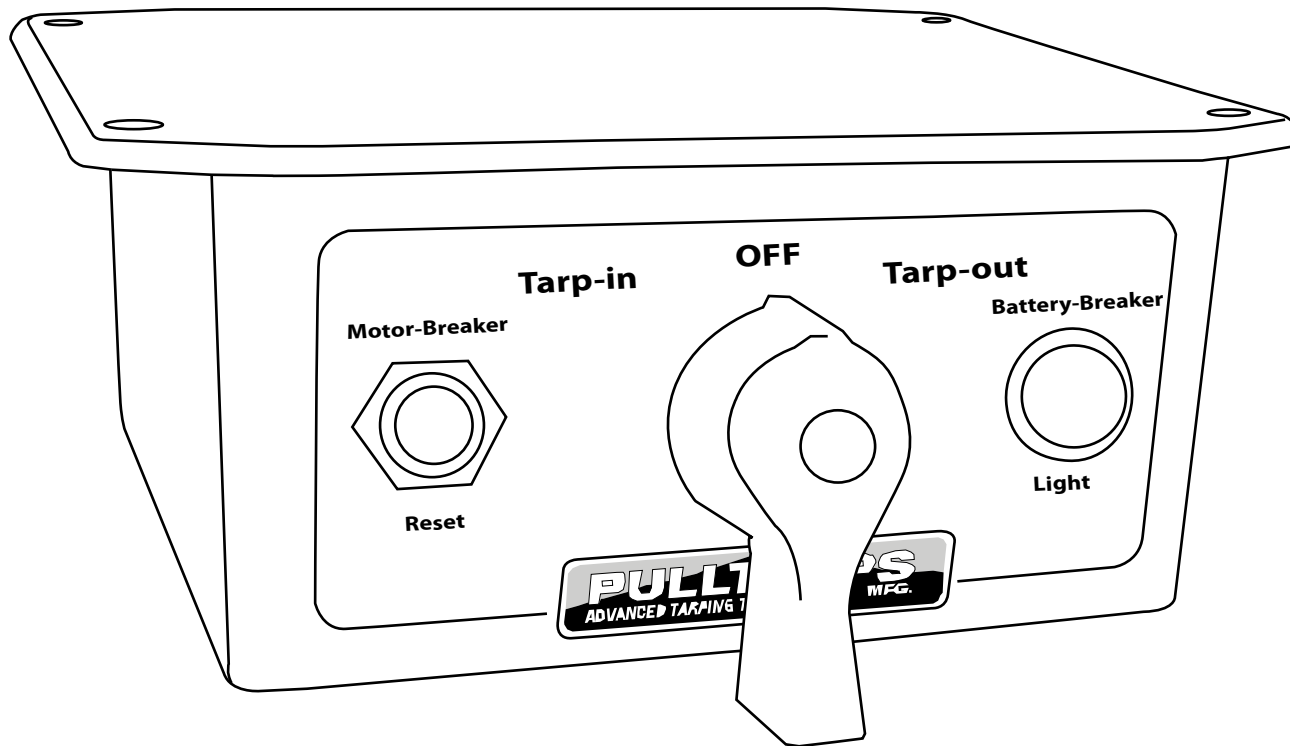

1404 N. Marshall Ave, El Cajon, CA 92020
For Technical Assistance
Call Toll Free: (800) 368-3075

Step. 1

Run the 6 ga. wire to both locations (motor & battery box) and attach to truck body as shown in Fig. 1.

Note: The wire must go beyond the pivot point.

Caution: Make sure wire does not get pinched at the pivot.

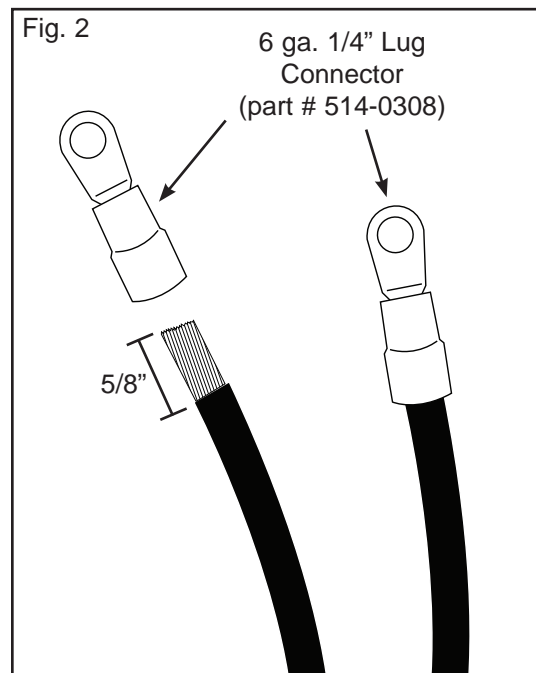
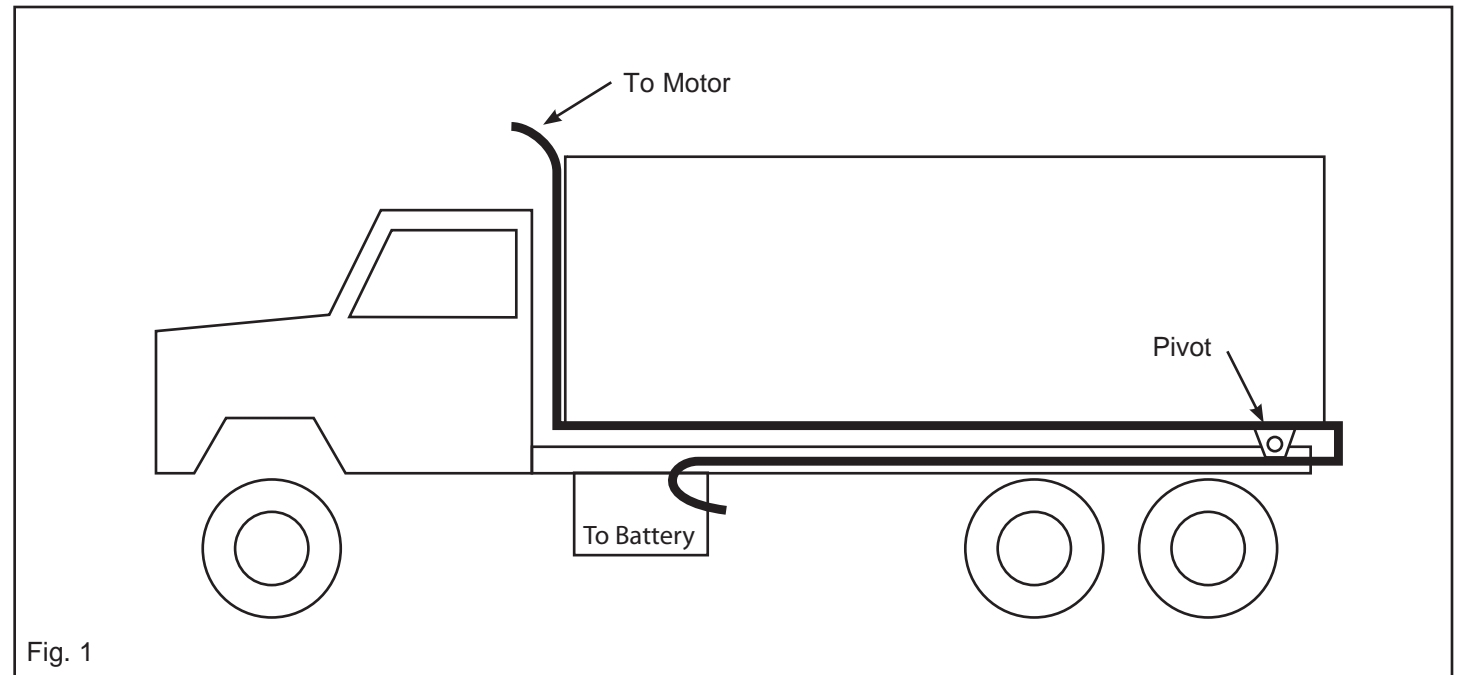

Step 2. Attaching The Connectors (Motor)

- Split the molded 6 ga. wire approximately 4" and strip the ends about 5/8" down.
- Attach connectors (part # 514-0308) and crimp (Fig. 2).
- Attach black wire to Terminal # 1 on motor (Fig. 3).
- Attach red striped wire to Terminal # 2 on motor (Fig. 3).

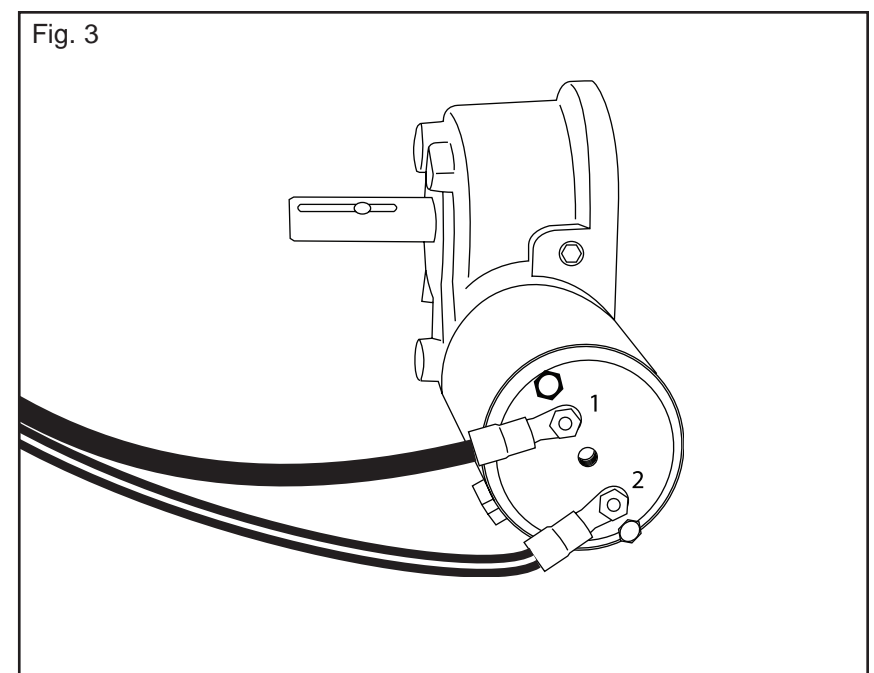
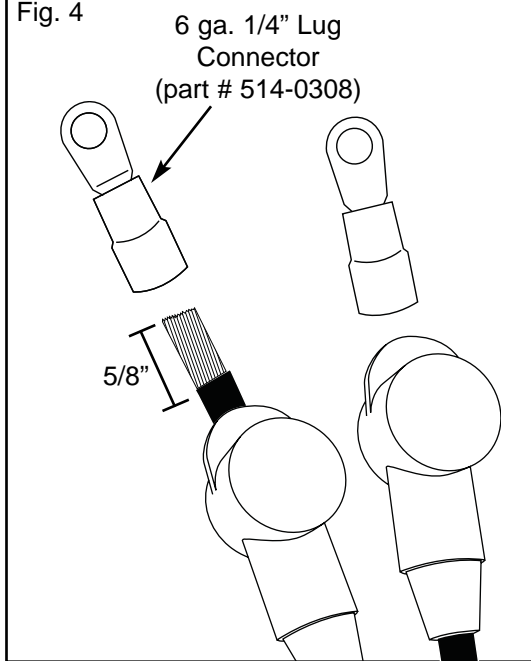

Fig. 4



Step 3.

- A. Mount the Control Box in a convenient location.
- B. Split the 6 ga. wire at the Control Box about 4" back and slip on rubber boots - Red Boot (part # 514-0319) on red striped wire and Black Boot (part # 514-0317) on black wire (Fig. 4 & 5).
- C. Strip wire about 5/8" and attach connectors (part # 514-0308) (Fig. 4). Crimp Connectors.
- D. Attach Red Striped wire to Motor (+) and Black wire to Motor (-) on Control Box (Fig. 5).

Do not over tighten nuts on connections!

Fig. 5

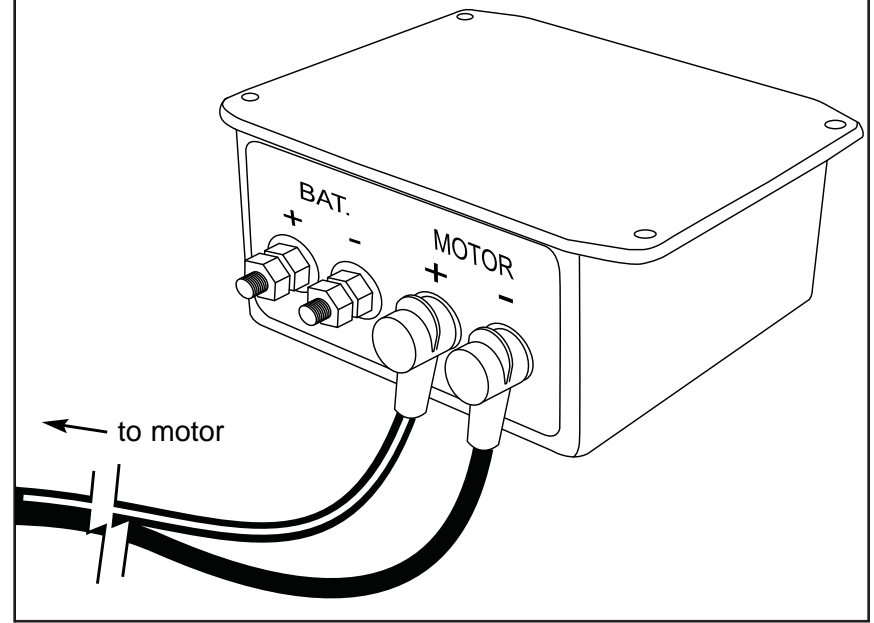

Step 4. Wiring the Breaker

- A. Mount breaker in the battery box away from moisture.
- B. Cut a section in the red 6 ga. wire that will run to the positive terminal on the battery.
- C. Strip the ends about 5/8" and attach the 6 ga. #10 terminal ends (Part # 514-0307).
- D. Attach to breaker.

Fig. 6

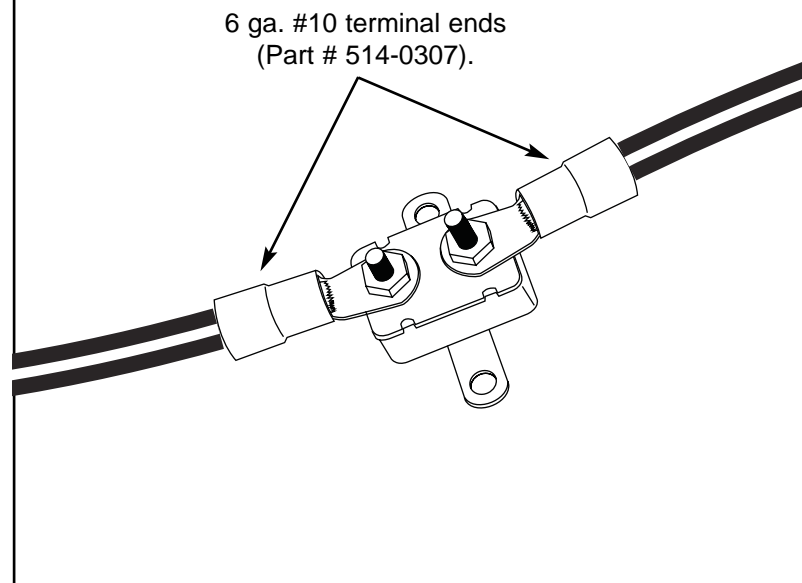

Step 5. Wiring the Battery

- A. Attach the red striped 6 ga. wire to BAT (+) at the control box. Slide Red Terminal Boot over the end and connect using the Lug Connector (part # 514-0308) as done in step 3.
- B. Attach the other end of the red striped 6 ga. wire to the positive terminal on the battery using a 6 ga. 3/8" terminal end (part # 514-0309) or 1/4" terminal end (part # 514-0308), depending on the size of the terminal at the battery. (Fig. 7).

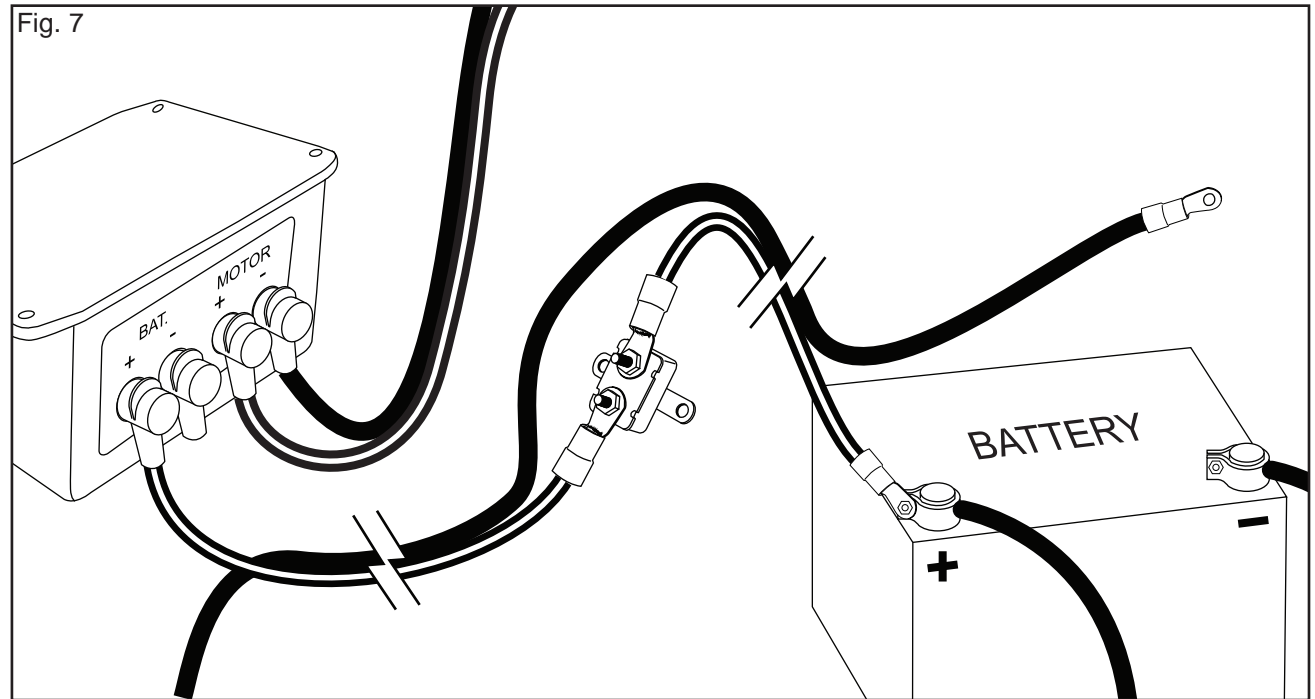

Step 6. Wiring the Battery

- A. Connect the black 6 ga. wire to the negative terminal on the battery using a 6 ga. 3/8" terminal end (part # 514-0309) or 1/4" terminal end (part # 514-0308), depending on the size of the terminal at the battery. (Fig. 8).
- B. Attach the other end of the black 6 ga. wire to BAT (-) at the control box as done in step 3. Slide Black Terminal Boot over the end and connect using the Lug Connector (part # 514-0308) as shown in Fig. 8.

Warning: You must attach the black 6 ga. wire to the battery first, before attaching it to the box.

Note: If the system operates backwards then reverse the 6 ga. wires on the motor.

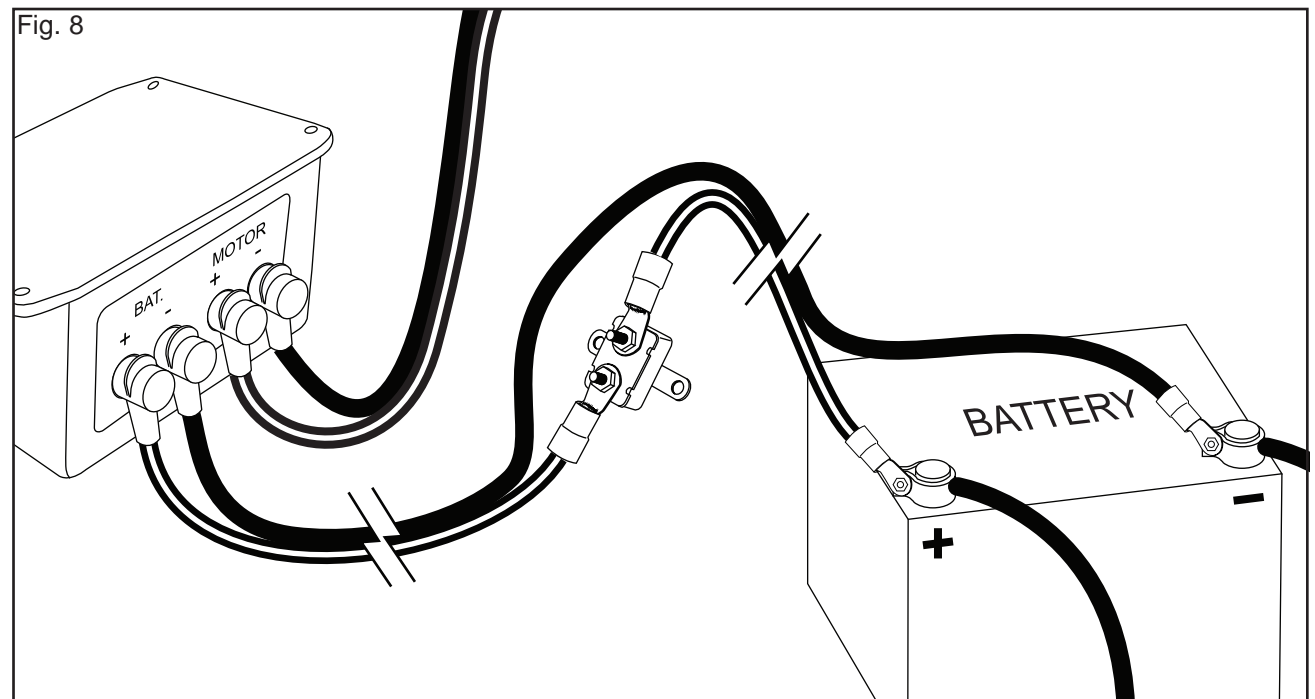

40 Amp Electrical Switch Assembly Enclosed (514-0105) Pre-Wired Weatherproof Switch

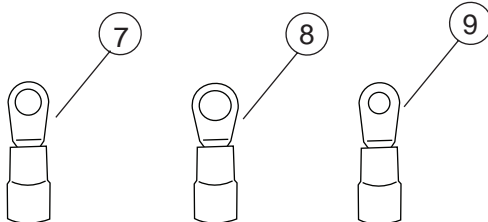
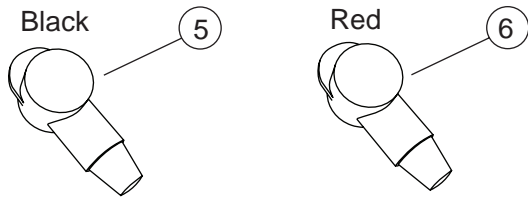
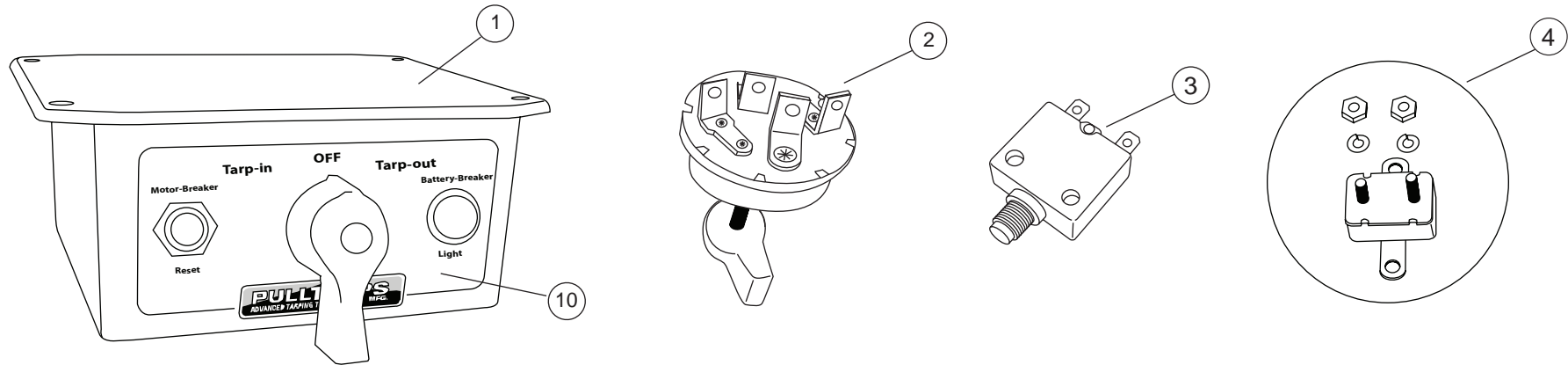

Item #	Part #	Description:	QTY:
1	514-9906	Enclosure for Electric Switch	1
2	514-0107	Electric Switch 3 Position	1
3	514-0406	40 Amp "Push to Rest Breaker"	1
4	514-0405	40 Amp Type II Breaker	1
5	514-0317	Black Terminal Boot	2
6	514-0319	Red Terminal Boot	2
7	514-0308	Connector 6 ga. Lug with 1/4" Eyelet	8
8	514-0309	Connector 6 ga. Lug with 3/8" Eyelet	2
9	514-0307	Connector 6 ga. #10 Stud	2
10	517-0213	40 Amp Electric Switch Label	1



1404 N. Marshall Ave, El Cajon, CA 92020
For Technical Assistance
Call Toll Free: (800) 368-3075