



A Safe Fleet Brand



**Installation Instructions**

**Supplemental Instructions for Reliance Transfers**

501-0613 & 501-0614

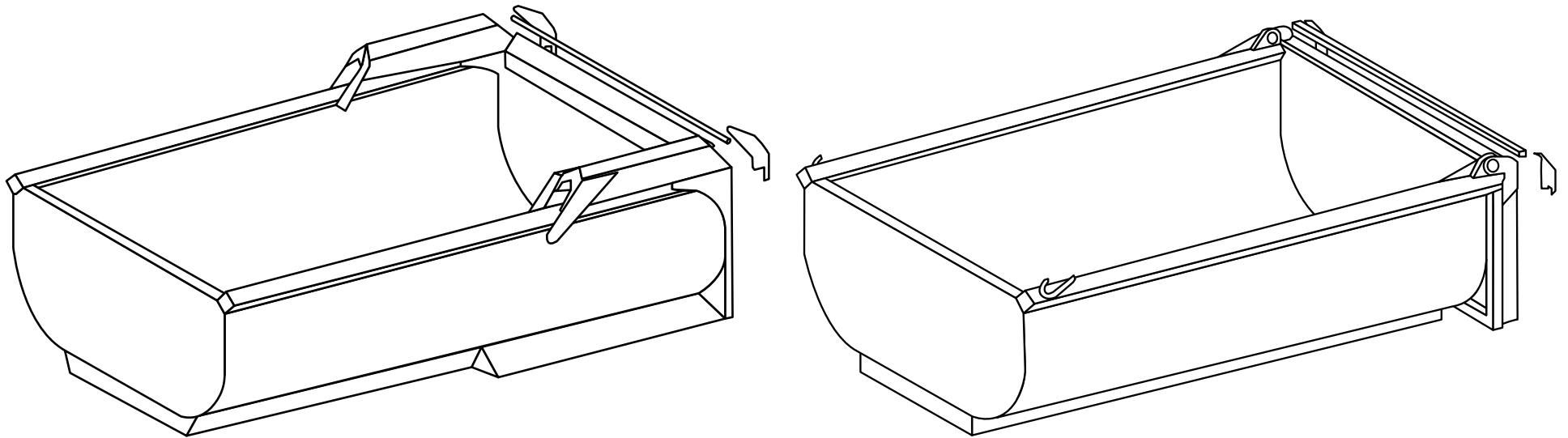



A Safe Fleet Brand



**Installation Instructions**

**Supplemental Instructions for Reliance Transfers**

**TABLE OF CONTENTS**

\*\*\*Parts\*\*\*

\*\*\*\*Assembly\*\*\*

Reliance Front H/W Kit #501-0613 .....	2	Front End - Part # 501-0613 .....	5
Reliance Rear H/W Kit #501-0614 .....	3	Rear Box - Part # 501-0614 .....	6



A Safe Fleet Brand



Installation Instructions

Supplemental Instructions for Reliance Transfers

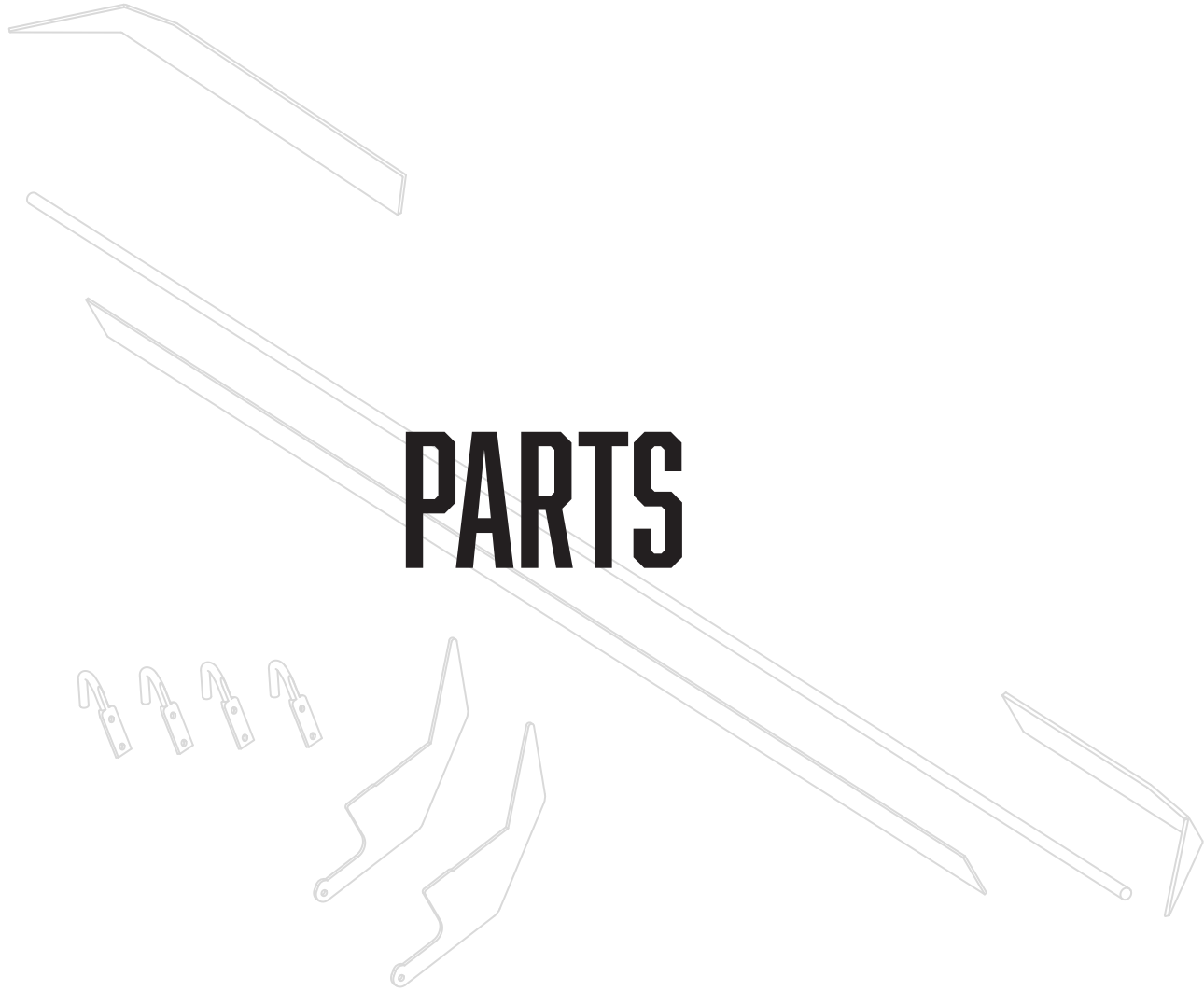



A Safe Fleet Brand



### Installation Instructions

### Supplemental Instructions for Reliance Transfers

#### Reliance Front H/W Kit #501-0613

ITEM	PART #	DESCRIPTION	QTY
1	501-0309	Tarp Return Ramp	2
2	501-0312	Left Bridge Ramp	1
3	501-0313	Right Bridge Ramp	1
4	501-0314	RW 1/8" x 2" x 77" Steel	1
5	501-0315	RW 1/2" Round Solid 96"	1
6	501-0616	Steel Tie Down Rope Hook	1

REV. 02/28/18 WLH

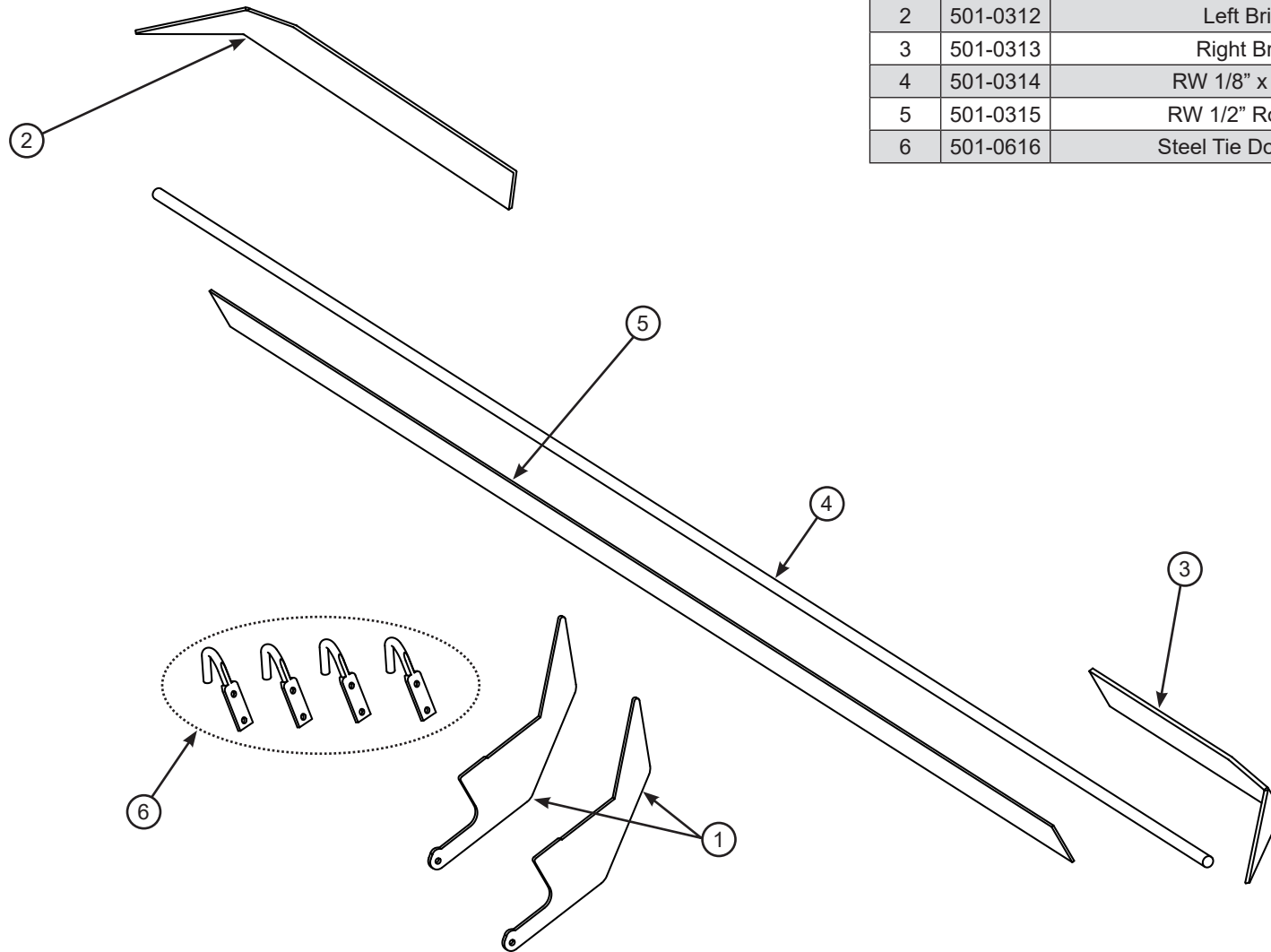



A Safe Fleet Brand



**Installation Instructions**

**Supplemental Instructions for Reliance Transfers**

**Reliance Rear H/W Kit #501-0614**

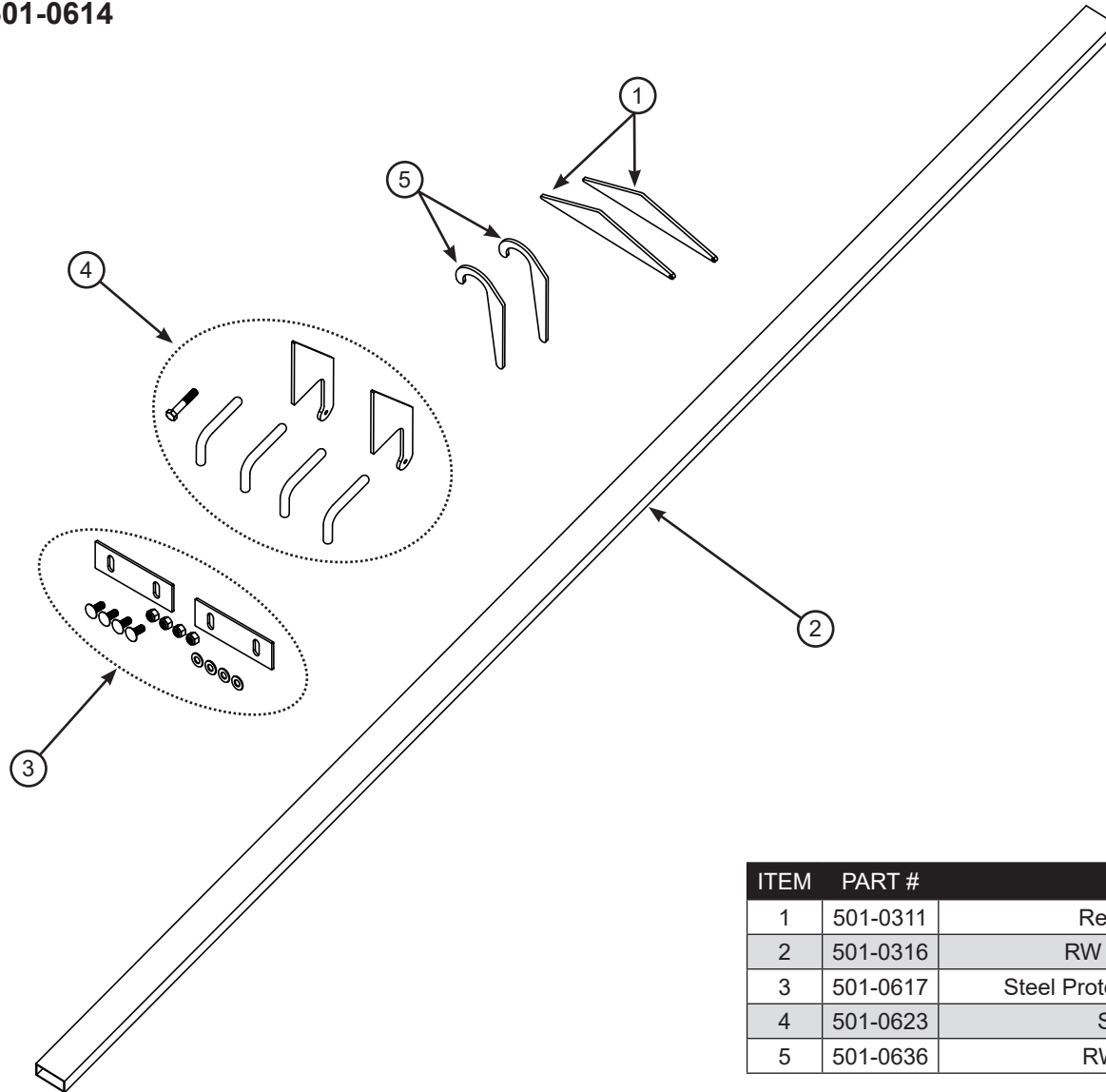

ITEM	PART #	DESCRIPTION	QTY
1	501-0311	Reliance Hinge Ramp	2
2	501-0316	RW 1" x 2" x 93-1/2" Box	1
3	501-0617	Steel Protector System Hardware Kit	1
4	501-0623	Steel Rope Hooks	1
5	501-0636	RW Centering Hooks	2

REV. 08/31/20 WLH



A Safe Fleet Brand



**Installation Instructions**

**Supplemental Instructions for Reliance Transfers**

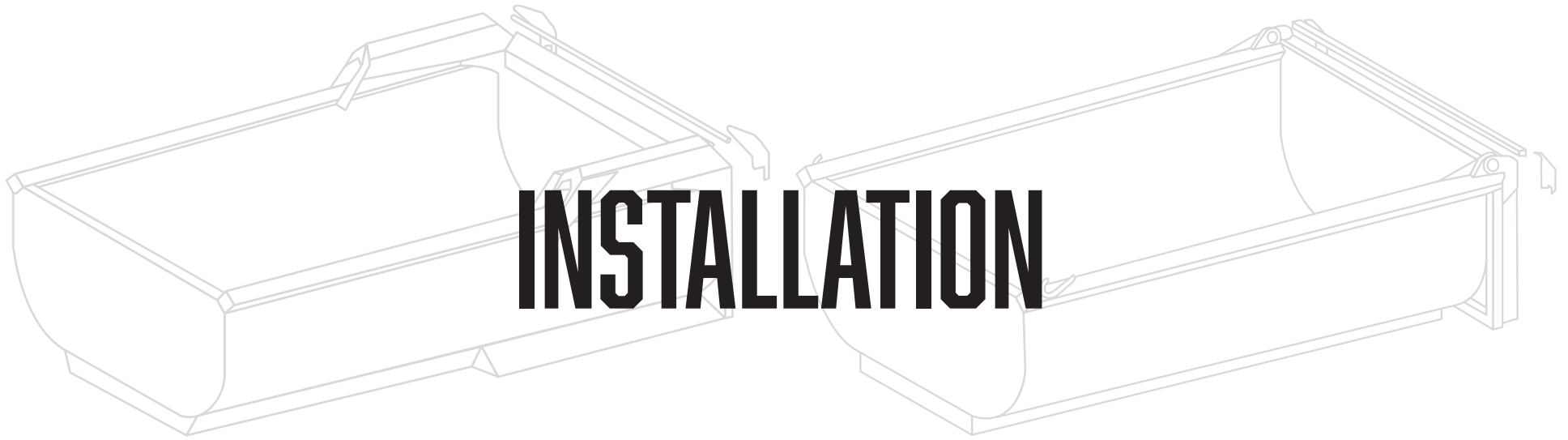



## Installation Instructions

## Supplemental Instructions for Reliance Transfers

### Front End - Part # 501-0613

#### Step 1: Tarp Return Ramps

The Tarp Return Ramps should be centered to the peak on the tail gate arms and welded in place (Fig. 1).

#### Step 2: 1/2" Round Bar Stock

Tack Weld the 1/2" Round Bar Stock to the top edge of the angled deflector at the rear of the box and weld to the tarp return ramps on each end (Fig.1). This provided a smooth surface for the tarp to slide on.

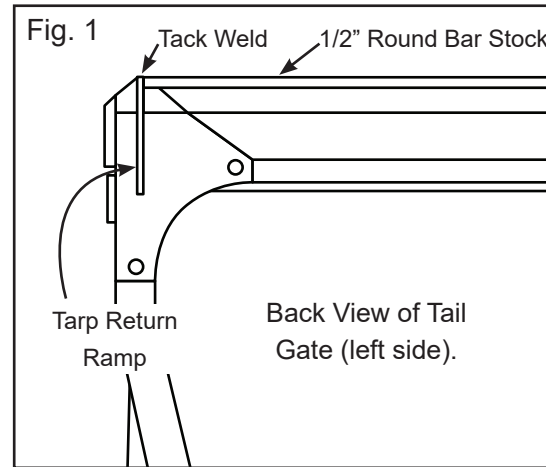

#### Step 3: Rope Centering Guide

Mark the center of the 1/2" Round Bar Stock and grind a smooth notch or heat dimple to provide a rope centering guide (Fig. 2 & 3). This is important because the diamond top rail makes it possible for the pullrod to fall into the box if the rope is not centered when pulling out or retracting the tarp.

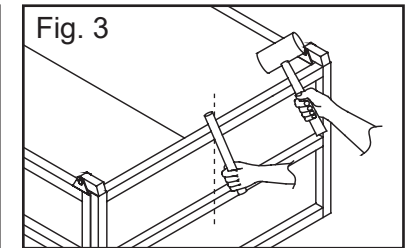
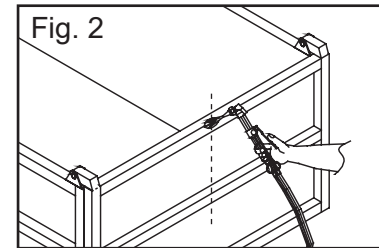

#### Step 4: Grind Down Rough Edges

Some edges on the body are very sharp. Grind down any sharp edges so that the tarp will not get damaged when it is pulled over the body and tail gate.

#### Step 5: Reliance Hinge Ramp

This kit enables the Pullrod to roll up and over the arms and return without getting hung-up. First, tack weld the pointed angled end of the Hinge Ramp to the angled front plate of the hinge assembly. Weld as high as possible but not on top of the arm (Fig. 4). **DO NOT WELD GUSSET TO THE BOX.** The Hinge Ramp must be able to rotate freely inside the box as the arm lifts the tailgate.

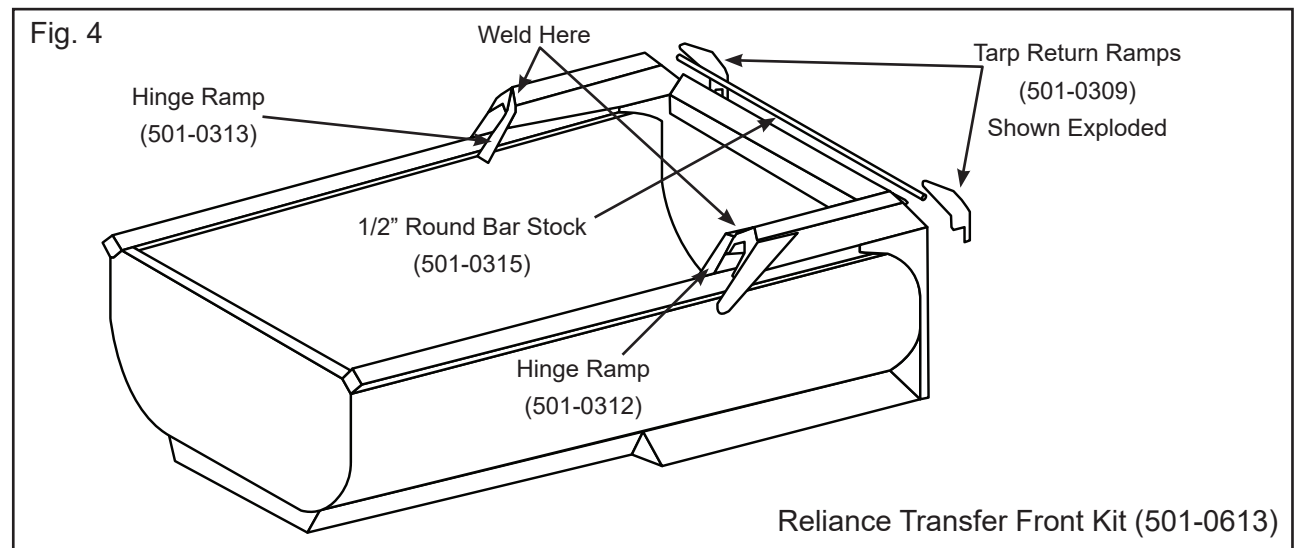

#### Step 6: Re-install Tarp and Test

Reliance Transfer Front Kit (501-0613)



## Installation Instructions

## Supplemental Instructions for Reliance Transfers

### Rear Box - Part # 501-0614

#### Step 1: Hinge Ramp Gussets

The Hinge Ramp Gussets allow the Pullrod to roll up and over the tail gate assembly. It welds to the top edge of the diamond rail and hinge. (Fig. 5).

#### Step 2: Tarp Return Ramps

The Tarp Return Ramps for the rear box should be positioned with the point at the top just past the radius of the hinge so the pullrod will return smoothly (Fig. 5).

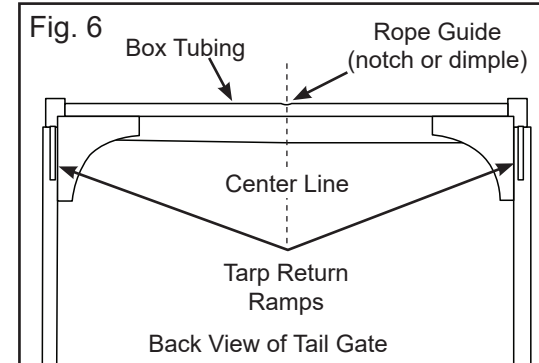
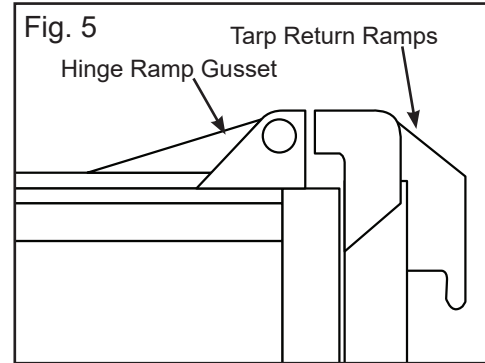

#### Step 3: 1"x 2"x 93-1/2" Box Tubing

Weld the Box tubing on top of the tail gate as far back as possible (Fig. 6). The Box Tubing will allow the tarp to pass over the tail gate without cutting the tarp.

#### Step 4: Rope Centering Guide

Once the box tubing is welded in place, mark the center of the tube and heat dimple to provide a rope centering guide (Fig. 6-8).

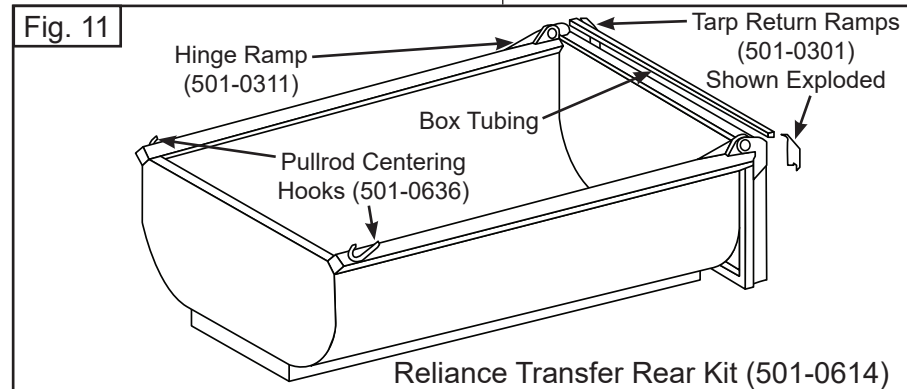
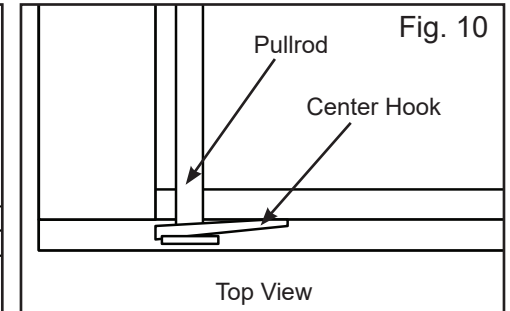
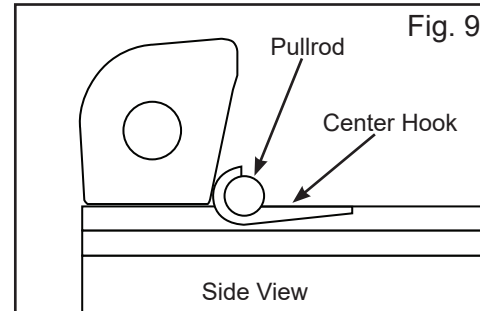
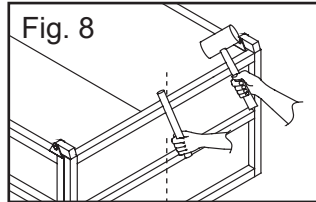
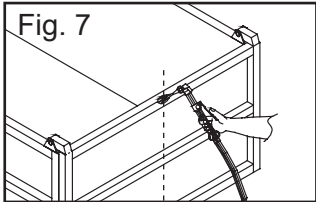

#### Step 5: Pullrod Centering Hook

To prevent pullrod damage, center the pullrod on the top rails for a guide. Weld the Centering Hooks in place as shown (Fig. 9 & 10).

**WARNING:** When transferring the rear box with the tarp retracted, the pullrod must be centered.

#### Step 6: Re-install Tarp and Test